

TM 11-6625-524-14-4

TECHNICAL MANUAL

**OPERATOR'S, ORGANIZATIONAL,
DIRECT SUPPORT AND GENERAL SUPPORT
MAINTENANCE MANUAL**

FOR

**VOLTMETER, ELECTRONIC AN/URM-145D
(MILLIVAC INSTRUMENTS MODEL MV-828A)
(NSN 6625-01-119-7271)**

HEADQUARTERS, DEPARTMENT OF THE ARMY

24 MAY 1982



5

SAFETY STEPS TO FOLLOW IF SOMEONE IS THE VICTIM OF ELECTRICAL SHOCK

1

DO NOT TRY TO PULL OR GRAB THE INDIVIDUAL

2

IF POSSIBLE , TURN OFF THE ELECTRICAL POWER

3

IF YOU CANNOT TURN OFF THE ELECTRICAL-POWER, PULL, PUSH, OR LIFT THE PERSON TO SAFETY USING A WOODEN POLE OR A ROPE OR SOME OTHER INSULATING MATERIAL

4

SEND FOR HELP AS SOON AS POSSIBLE

5

AFTER THE INJURED PERSON IS FREE OF CONTACT WITH THE SOURCE OF ELECTRICAL SHOCK, MOVE THE PERSON A SHORT DISTANCE AWAY AND IMMEDIATELY START ARTIFICIAL RESUSCITATION

CHANGE }
 No. 1 }

HEADQUARTERS
 DEPARTMENT OF THE ARMY
 Washington, DC, 13 February 1984

OPERATOR'S, ORGANIZATIONAL, DIRECT SUPPORT,
 AND GENERAL SUPPORT MAINTENANCE MANUAL
 FOR
 VOLTMETER, ELECTRONIC AN/URM-145D
 (MILLIVAC INSTRUMENTS MODEL MV-828A)
 (NSN 6625-01-119-7271)

TM 11-6625-524-14-4, 24 May, 1982, is changed as follows:

1. New or changed material is indicated by a vertical bar in the margin of the page.
2. Added or revised illustrations are indicated by a vertical bar in front of the figure caption.
3. Remove and insert pages as indicated below:

Remove

i and ii
 1-1 and 1-2
 3-1 and 3-2
 4-1 through 4-4
 5-5 and 5-6
 Figure F0-1
 Figure F0-2

Insert

i and ii
 1-1 and 1-2
 3-1 and 3-2
 4-1 through 4-4
 5-5 and 5-6
 Figure F0-1
 Figure F0-2

4. File this change sheet in front of the publication for reference purposes.

By Order of the Secretary of the Army:

Official:

JOHN A. WICKHAM JR.
General, United States Army
Chief of Staff

ROBERT M. JOYCE
Major General, United States Army
The Adjutant General

DISTRIBUTION:

To be distributed in accordance with DA Form 12-36B requirements for AN/URM-145.

OPERATOR'S, ORGANIZATIONAL, DIRECT SUPPORT,
 AND GENERAL SUPPORT MAINTENANCE MANUAL
 FOR
 VOLTMETER, ELECTRONIC AN/URM-145D
 (MILLIVAC INSTRUMENTS MODEL MV-828A)
 (NSN 6625-01-119-7271)

REPORTING ERRORS AND RECOMMENDING IMPROVEMENTS

You can help improve this manual. If you find any mistakes or if you know of a way to improve the procedures, please let us know. Mail your letter, DA Form 2028 (Recommended Changes to Publications or Blank Forms), or DA Form 2028-2 located in the back of this manual direct to: Commander, US Army Communications - Electronics Command and Fort Monmouth, ATTN: DRSEL-ME-MP, Fort Monmouth, New Jersey 07703.

In either case, a reply will be furnished direct to you.

TABLE OF CONTENTS

	Paragraph	Page
CHAPTER 1. INTRODUCTION		
Section I. General		
Scope	1-1	1-1
Consolidated index of Army publications and blank forms	1-2	1-1
Maintenance forms, records and reports	1-3	1-1
Reporting equipment improvement recommendations (EIR)	1-4	1-1
Administrative storage	1-5	1-1
Destruction of Army electronics materiel	1-6	1-1
II. Description and data		
Description and use	1-7	1-1
Technical characteristics	1-8	1-2
CHAPTER 2. INSTALLATION		
Packaging data	2-1	2-1
Unpacking	2-2	2-1
Checking unpacked equipment	2-3	2-1
Items comprising an operable equipment	2-4	2-1

This manual is an authentication of the manufacturer's commercial literature which, through usage, has been found to cover the data required to operate and maintain this equipment. Since the manual was not prepared in accordance with military specifications and AR-310-1, the format has not been structured to consider levels of maintenance.

		Paragraph	Page
CHAPTER 3	OPERATING INSTRUCTIONS		
	General	3-1	3-1
	Power Line Requirements	3-2	3-1
	General precautions for RF measurements	3-3	3-1
	Control sand indicators	3-4	3-1
	Operating procedures	3-5	3-1
CHAPTER 4	CIRCUIT FUNCTIONING		
	General	4-1	4-1
	Detailed description, voltmeter	4-2	4-1
	Detailed description, probe and terminations.	4-3	4-5
CHAPTER 5	GENERAL SUPPORT MAINTENANCE INSTRUCTIONS		
Section I.	Tools and Test Equipment		
	Tools and test equipment required	5-1	5-1
	Cabinet removal	5-2	5-2
II.	Troubleshooting		
	General	5-3	5-2
	Inoperative	5-4	5-3
	Erratic or intermittent.	5-5	5-3
	DC modulator driver	5-6	5-3
	Post amplifier, synchronous demodulator and reference amplifier	5-7	5-3
	Narrow band pre-amplifier	5-8	5-4
	DC modulator	5-9	5-4
	Power and range switches	5-10	5-5
	Feedback, linearizing and calibration controls network	5-11	5-5
III.	Maintenance		
	Probe and diode cartridge	5-12	5-5
	Probe terminations	5-13	5-7
	Switch cleaning	5-14	5-7
CHAPTER 6	GENERAL SUPPORT TESTING PROCEDURES		
	General	6-1	6-1
	Test equipment required	6-2	6-1
	Power supply test	6-3	6-1
	Pre-amplifier and post amplifier test	6-4	6-2
	Voltage accuracy test	6-5	6-3
CHAPTER 7	SHIPMENT AND LIMITED STORAGE AND DEMOLITION TO PREVENT ENEMY USE		
Section I.	Shipment and limited storage		
	Disassembly of equipment	7-1	7-1
	Repackaging for shipment or limited storage	7-2	7-1
II.	Demolition of materiel to prevent enemy use		
	Authority for demolition	7-3	7-1
	Methods of destruction	7-4	7-2

Table of Contents (Continued)

		Page
APPENDIX A	REFERENCES	A-1
B	COMPONENTS OF END ITEM LIST	
Section	I. Introduction	B-1
	II. Integral components of end item	B-3
	III. Basic issue items	B-4
APPENDIX C	ADDITIONAL AUTHORIZATION LIST (Not applicable)	
D	MAINTENANCE ALLOCATION	
Section	I. Introduction	D-1
	II. Maintenance Allocation Chart	D-3
	III. Tool and Test Equipment Requirements	D-4
	IV. Remarks	D-5
APPENDIX E	EXPENDABLE SUPPLIES AND MATERIALS LIST (Not applicable)	

LIST OF ILLUSTRATIONS

Figure No.	Title	Page
1-1	Typical frequency response for 0 dBm level	1-2
2-1	Voltmeter, Electronic AN/URM-145D	2-2
3-1	Front panel controls and indicators	3-4
3-2	Rear panel controls	3-4
4-1	Block diagram	4-2
4-2	Linearizing correction network	4-4
4-3	Probe input impedance vs level and frequency	4-5
4-4	Probe input capacitance vs level	4-6
4-5	VSWR curve for 50-ohm termination adapter	4-6
5-1	Maintenance equipment test set-up	5-1
5-2	Probe and diode cartridge assembly	5-7
6-1	Pre-amplifier and post amplifier test set-up	6-2
F0-1	Schematic diagram, amplifier board assembly	
F0-2	Schematic diagram, power supply board assembly, range switch and power switch	

CHAPTER 1 INTRODUCTION

Section I. GENERAL

1-1 SCOPE

This manual describes Voltmeter, Electronic AN/URM-145D and provides operator and maintenance instructions, testing procedures and schematic diagrams.

1-2 CONSOLIDATED INDEX OF ARMY PUBLICATIONS AND BLANK FORMS

Refer to the latest issue of DA Pam 310-1 to determine whether there are new editions, changes, or additional publications pertaining to this equipment.

1-3 MAINTENANCE FORMS, RECORDS, AND REPORTS

a. Reports of Maintenance and Unsatisfactory Equipment. Department of the Army forms and procedures used for equipment maintenance will be those described by TM 38-750, The Army Maintenance System.

b. Report of Packaging and Handling Deficiencies. Fill out and forward SF 364 (Report of Discrepancy (ROD)) as prescribed in AR 735-11-2/DLAR 4140.55/NAVMATINST 4355.73A/AFR 400-54/MCO 4430.3F.

c. Discrepancy in Shipment Report (DISREP) (SF 361). Fill out and forward Discrepancy in Shipment Report (DISREP) (SF361) as prescribed in AR 55-38/NAVSUPINST 4610.33C/AFR 75-18/MCO P4610.19D/DLAR 4500.15.

1-4 REPORTING EQUIPMENT IMPROVEMENT RECOMMENDATIONS (EIR)

If your AN/URM-145D needs improvement, let us know. Send us an EIR. You, the user, are the only one who can tell us what you don't like about your equipment. Let us know why you don't like the design. Tell us why a procedure is hard to perform. Put it on an SF 368(Quality Deficiency Report). Mail it to Commander, US Army Communications-Electronics Command and Fort Monmouth, ATTN: DRSEL-ME-MP, Fort Monmouth NJ 07703. We'll send you a reply.

1-5 ADMINISTRATIVE STORAGE

Administrative storage of equipment issued to and used by Army activities shall be in accordance with TM 740-90-1.

1-6 DESTRUCTION OF ARMY ELECTRONICS MATERIEL

Destruction of Army electronics materiel to prevent enemy use shall be in accordance with TM 750-244-2.

Section II. Description and Data

1-7 DESCRIPTION AND USE

a. Voltmeter, Electronic AN/URM-145D is a sensitive, wide band instrument for the measurements of voltages from 100 microvolt (μV) to 3 volts (V) spanning a frequency range of 20 kilohertz (KHz) to 600 megahertz (MHz).

b. The general purpose probe supplied employs a fullwave germanium diode detecting circuit. In the square-law region(100 μV to 30mV) the voltmeter is true RMS responding. In the transition region(30mV to 1V)the characteristics of the probe's detecting circuit changes gradually from RMS to peak. In the linear region (1V to 3V) the voltmeter is peak responding.

c. The type BNC 50-ohm termination adapter supplied has a VSWR of less than 1.2:1 up to 600MHz. The adapter has a 5 watt max. power rating.

d. The high impedance probe tip supplied allows for direct high impedance measurements up to 250MHz. However, a short wire should be substituted for the ground lead when using above 100MHz to minimize the effects of ground lead induction.

e. The main controls required to operate the voltmeter are on the front panel. Several minor controls are on the rear panel.

1-8 TECHNICAL CHARACTERISTICS

Voltage range 100μV to 3V, 8 ranges; 0.001V to 3V full scale
 dBm range -60 to + 23, 8 ranges in 10dB steps per range
 Frequency range 20KHz to 600MHz
 Frequency response True RMS up to 30mV, peak reading above 1V
 Wide band accuracy (see Fig. 1-1)

<u>Frequency</u>	<u>0.001V Full Scale Range</u>	<u>0.003V Full Scale to 3V Full Scale Ranges</u>
20KHz to 100MHz	±15% of full scale	±10% of full scale
100MHz to 400MHz	±10% of full scale	±5% of full scale
400MHz to 600MHz	±15% of full scale	±10% of full scale

INPUT IMPEDANCE	Approx. 2.2 pf and 200KΩ
V.S.W.R.	Less than 1.2:1 at 600MHz
CREST FACTOR	450 to 1.4 (function of input voltages)
MAXIMUM INPUTS	RF: 42V P-P or 15V RMS; DC: 400V
DC OUTPUT	1.0V, 1mA max. at full scale, linear. Impedance load of 2KΩ, ±1% required
RISE TIME	1 sec. on the 0.001V full scale range, decreasing to 100 millisecond. about the 0.01V full scale range
INDICATOR	Precision 5.5" taut band meter movement, mirror-backed dial and knife edge pointer. Expanded linear dial scales except dBm.
LINE VOLTAGE & POWER	115V or 230V AC +20%, 45-1000Hz; less than 12W
DIMENSIONS&WEIGHT	9" H x 6.5"W x 11.25" D. Weight approx. 12 lbs.

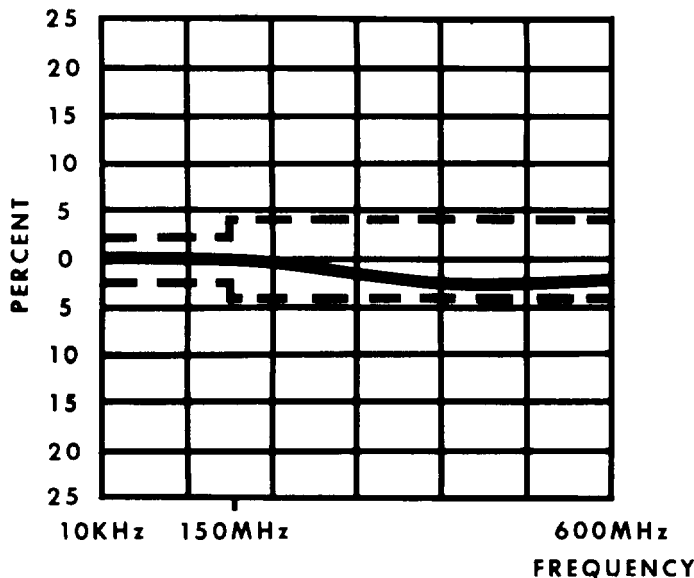

Figure 1-1: Typical frequency response for 0dBm level.

CHAPTER 2
INSTALLATION

2-1 PACKAGING DATA

- a. Voltmeter, Electronic AN/URM-145D may arrive packed for either domestic or overseas shipment.
- b. When Voltmeter, Electronic AN/URM-145D is packed for overseas shipment, it is placed in a corrugated carton surrounded with packing material. The carton is sealed with gummed tape. The boxed equipment is then placed in a moisture-vapor-proof barrier, which is heatsealed, and this package is placed in a waterproof corrugated carton. The technical manual is placed under the lid and the carton is sealed with waterproof tape.

2-2 UNPACKING

- a. For unpacking overseas shipment equipment proceed as follows:
 - (1) Open the outer corrugated carton and break the sealed moisture-vapor-proof barrier. Lift out the inner corrugated carton.
 - (2) Open the inner corrugated carton. Remove the equipment in its packing material and remove the packing material.
- b. For unpacking domestic shipment the instructions above also apply. If a heavy wrapping paper has been used, remove it carefully and take out the equipment.

2-3 CHECKING UNPACKED EQUIPMENT

- a. Inspect the equipment for damage incurred during shipment. If the equipment has been damaged, report the damage on SF 364 (para 1-3b).
- b. Check the equipment for completeness against the packing slip. Report all discrepancies in accordance with paragraph 1-3. The equipment should be placed in service even though a minor part that does not affect proper functioning is missing.
- c. After the equipment has been thoroughly checked, clean all items with a soft cloth. Apply cleaning solvents only as necessary.

2-4 ITEMS COMPRISING AN OPERABLE EQUIPMENT (figure 2-1)

- a. Voltmeter, Electronic ME-247D/U.
- b. 3 wire grounded AC line power cord.
- c. Type BNC 50-ohm termination adapter.
- d. DC output phone plug.
- e. High impedance probe tip.
- f. RF probe type G.

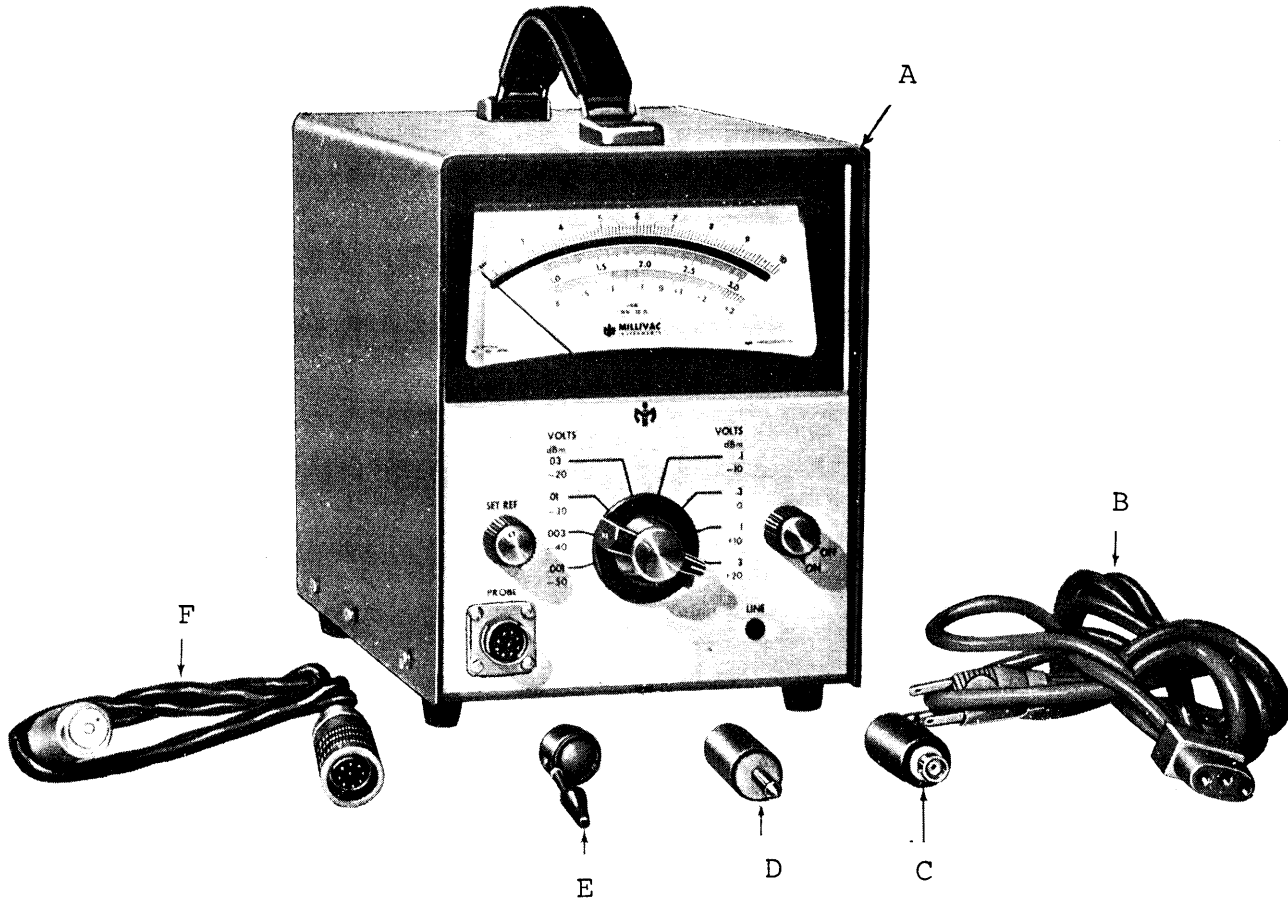

- A. Voltmeter, Electronic ME-247D/U
- B. 3 wire grounded AC line power cord
- C. Type BNC 50-ohm termination adapter
- D. DC output phone plug
- E. High impedance probe tip
- F. RF probe type G

Figure 2-1. Voltmeter, Electronic AN/URM-145D.

CHAPTER 3 OPERATING INSTRUCTIONS

3-1 GENERAL

This chapter should be read carefully before using the voltmeter. It contains information necessary for proper operation of the voltmeter. To achieve valid readings, proper switch settings are required. Controls, with the function of each, are listed in paragraph 3-4. The controls are shown in figures 3-1 and 3-2. Operating procedures are described in paragraph 3-5.

3-2 POWER LINE REQUIREMENTS

The voltmeter can be used on either 115 or 230V AC power line. A line voltage selector slide switch, located on the serial/power plate, must be set to agree with the line voltage to be used.

The voltmeter will operate on power line frequencies from 45Hz to 1000Hz. Unless otherwise specified, the AC line rejection (input) filter, is adjusted for use on a 60Hz power line frequency. For operation on another power line frequency, it is advisable to retune the filter.

3-3 GENERAL PRECAUTIONS FOR RF MEASUREMENTS

NOTE

Maximum Allowable Overload: Damage to the diode cartridge may result should the following input limits be exceeded:

RF: 15V RMS or 42V P-P DC: 400V

NOTE

The manufacturer's warranty does not apply to burned-out diode cartridges.

- a. Overload recovery: Should any range be momentarily overloaded, especially the more sensitive ranges, it is advisable to turn the RANGE switch to the 0.03v full scale position to facilitate a faster overload recovery.
- b. Power dissipation rating: Termination adapters are designed for 5 watt dissipation. Do not exceed 5 watt RF.
- c. Mis-termination: High frequency signal generators have terminated output transmission lines. The terminating resistance, corresponding to the characteristics impedance of the transmission line, is usually installed between the output terminals at the free end of the transmission line. Some generators may have the transmission line terminated in its characteristic impedance internally at the output connector. In this case, if the external transmission line is also in 50Ω, serious measuring errors may result. To avoid this mis-match, the user must check the generator in question to determine if the line is internally terminated. If such is the case, the resistor should be disconnected, allowing the 50Ω termination of the voltmeter's probe to become the required output matching resistance. If it is not desirable to remove the internal termination resistor, an open circuit adapter should be used.
- d. Measurements using the Hi Impedance Tip: Care must be exercised in measuring low signal levels because of possible stray RF pick-up. The lowest level at which the tip is useful will depend upon the strength of the stray RF field. Since the probe is a very wide-band device (20KHz to 600MHz), any RF signal present within the probe's response (AM-FM-TV broadcasting, point-to-point communications, etc.) may be detected. In addition, above 100MHz, the inductance of the tip and ground lead, Plus the probe's shunt capacitance, may cause resonances, creating large measuring

errors. However, the probe is still useful for relative readings. Because of its shunt capacitance and resistance, the effective impedance drops appreciable above 100MHz.

3-4 CONTROLS AND INDICATORS

- a. Front panel (figure 3-1)
 - (1) POWER Switch - a two position ON-OFF switch. Connects AC power to the voltmeter at the ON position.
 - (2) RANGE Selector Switch - enables the selection of any one of the eight (8) RF voltage or dBm measuring ranges.
 - (3) SET REF Adjust Control - is used to electrically zero the voltmeter, under no input signal conditions, to the meter's SET REF indication.
 - (4) Meter - RF voltage measurements are read on the top two (2) meter's dial scales. All measurements should be read between 30% and 100% of full scale as the specified accuracies will apply only to those readings. The 1 and 2 marks on the second dial scale refer to 100 μ V and 200 μ V and apply only to the .001V full scale range. dBm measurements are read on the dBm (1mV, 50 ohm) dial scale.
 - (5) Meter Mechanical Zero Adjust - provides mechanical zeroing of the meter pointer and is performed with the voltmeter de-energized.
 - (6) RF Input PROBE Connector - a 9 pin Amphenol type which accepts the probe.
 - (7) AC LINE Pilot Light - indicates AC power is applied to the voltmeter and is operational.
- b. Rear panel (figure 3-2)
 - (1) POWER Connector - accepts the 3 wire grounded AC line power cord. Voltage and frequency requirements are marked on the serial/power plate.
 - (2) FUSE Holder - contains a 0.3 amp "S1o-B1o" fuse. Always replace with the same type and manufacture as factory installed.
 - (3) LINE VOLTAGE Selector Switch - slide switch for either 115V or 230V AC line operation and must be set to agree with the line voltage to be used.
 - (4) DC OUTPUT Connector - phone type jack for obtaining a DC voltage which is directly proportional to the full scale reading of the meter. DC output 3 circuit phone plug furnished. Impedance load of 2K Ω (1.98K Ω to 2.02K Ω) is required.
 - (5) Serial/Power Plate.
 - (6) Calibration Controls Board.
 - (7) Calibration Adjust Controls - provides individual range linearization correction adjustments.

3-5 OPERATING PROCEDURES

Attach the probe to its front panel connector by lining up the key-way of the probe input connector with the mating key of the probe plug. Push the plug firmly into the connector and secure by rotating (clock-wise) the plug's collar until locked. Select the appropriate probe termination. Attach to the probe's threaded end, finger tight. Use the high impedance tip for direct measurement or use the 50-ohm termination adapter for measurements in 50-ohm systems.

Insert the 3 wire grounded AC line power cord into its polarized power connector. Ascertain that the line voltage selector switch is set to and agrees with the line voltage source to be used.

Prior to energizing the-voltmeter, check and if necessary, adjust the meter's mechanical zero. To re-adjust, slowly rotate the mechanical zero adjust screw until (SET REF) indication occurs. The adjustment is properly made only when the pointer is traveling in the direction opposite to the turn of the adjust screw.

Select the desired measuring range. If the level of measurement to be taken is unknown, turn the range selector switch to the 3V full scale range.

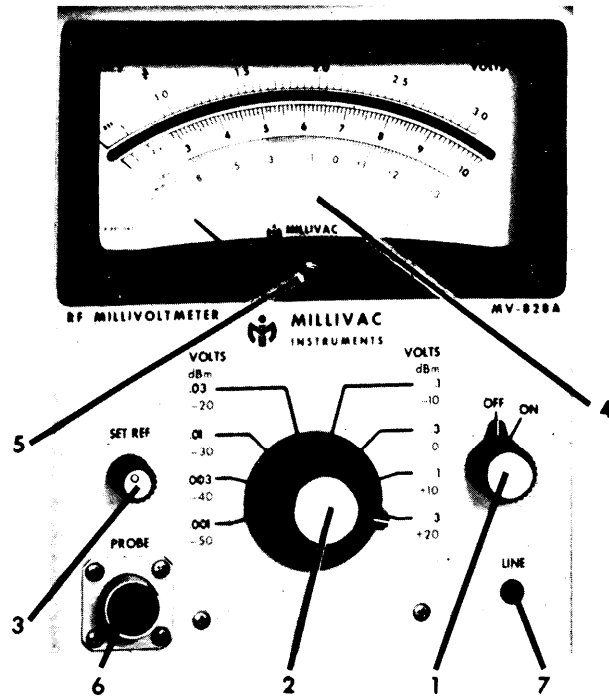

Figure 3-1. Front panel controls and indicators.

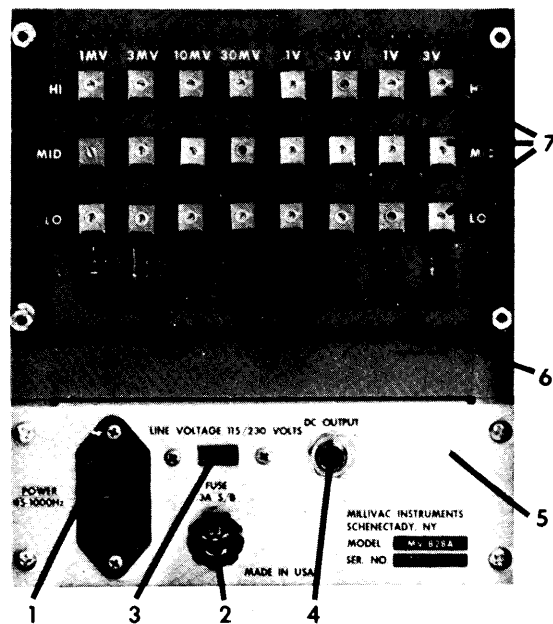

Figure 3-2. Rear panel controls.

Turn the POWER selector switch to ON. With the RF probe and its termination connected to the de-energized signal source, slowly rotate the SET REF adjust control until a SET REF indication occurs. This adjustment should be made carefully, especially on the lower, more sensitive ranges. The voltmeter is ready for use. If the level of measurement shows less than 30% of full scale, rotate the RANGE selector switch to a range position where the meter reading indicates between 30% and 100% of full scale. To obtain readings in dBm, add dBm meter reading (red scale on meter dial) to the dBm setting of the RANGE selector switch.

CAUTION

Damage to the probe's diode cartridge may result if the input exceeds 42V P-P, 15V RMS or 400V DC.

When measuring low level RF voltages, always take precautions to avoid the possibility of erroneous readings resulting from hum, noise or stray rf pickup. Although all low frequency hum and noise is attenuated at the input by 60dB, it is still possible for high level unwanted signals to get through and cause errors. The best test for this condition is to reduce the test signal to zero level and note whether the voltmeter continues to read some spurious signal level. In some cases, extra shielding may be necessary around the probe connections to reduce stray field pick-up. Typical sources of spurious radiation are induction or dielectric heating units, diathermy machines, local radio transmitters, grid dip meters, and amplifiers with parasitic oscillations.

Operation of the voltmeter in strong 60 Hertz (Hz) magnetic fields, such as those surrounding unshielded power transformers, should be avoided. The magnetic field induces small 60Hz currents in the amplifier section of the voltmeter which, due to the extremely high gain at this frequency, appear as an indication on the meter.

CHAPTER 4

CIRCUIT FUNCTIONING

4-1 GENERAL

The basic circuitry of the voltmeter is best understood by reference to the block diagram, figure 4-1.

- a. The input signal is sampled and detected by the rf probe. The direct current (dc) output signal from the probe, after passing through the attenuator section of the range selector switch, goes through an input filter which rejects power line frequency components which might cause a measuring error.
- b. A single-pole, double-throw, solid-state dc modulator then converts the dc signal into a nearly symmetrical square wave.
- c. The square wave is impedance matched and amplified by a high impedance, narrow band preamplifier. A narrow band filter in the preamplifier's feedback further improves the signal-to-noise ratio.
- d. The preamplifier output is further amplified in the post amplifier stage.
- e. The modulated alternating current (at) signal from the post amplifier stage is rectified by a synchronous demodulator and the resultant dc output is used to provide heavy overall dc feedback and is temperature compensated. The dc output is also linearized and is connected to the indicating meter.
- f. The dc modulator driver is connected to the dc modulator and to the reference amplifier.
- g. The output from the reference amplifier is fed to the synchronous demodulator. The phase relationship between the reference amplifier and the input signal determines the polarity of the dc output of the synchronous demodulator.
- h. An electronically regulated power supply delivers dc voltages to the amplifier.

4-2 DETAILED DESCRIPTION, VOLTMETER

For the following detailed descriptions of each circuit, the Schematic Diagrams (F0-1 and F0-2) should be used as reference sources as well as the Block Diagram, figure 4-1.

Due to the complexity of interconnections between the range selector switch and power selector switch to their circuit connections, these switches will not be detailed separately but will be integrated into the applicable circuit's description.

- a. RF probe and probe input circuit: The diode cartridge assembly (1A1), part of probe (1A3), contains a coupling capacitor, 2 matched diodes and 2 filter capacitors. The probe also contains 2 10K filter resistors and 3 feedback resistors in a sealed housing. The probe input connector (1J1) uses .001MF capacitors (1C1 thru 1C5) on its current carrying terminals to filter stray RF pick-ups which may enter the probe cable.
- b. Range attenuator: The range attenuator divider consists of resistors 1R3 thru 1R9. Depending upon the range switch position, the DC signal from the probe will either be sent directly to the input filter or will be attenuated prior to entering the input filter.
- c. AC line rejection (input) filter: Preceding the rejection filter is a R/C filter (consisting of 3R1, 3R2 and 3C1) and a clipping diode (3CR5). This filter and diode aid in reducing and limiting spurious signals from entering the rejection filter. The rejection filter consists of R/C network 3R3, 3R5, 3R64, 3R65 and 3C4 and a parallel "T" network consisting of 3C3, 3C5, 3R4 and 3R66. This filter is tuned for a minimum of -60dB rejection at the power line frequency. Unless otherwise specified, the filter is tuned for use on a power line frequency of 60Hz. It is advisable to retune the filter for line frequencies other than originally specified.

d. DC modulator: The DC modulator (3G1) is a plug-in solid state photo chopper. It converts the incoming DC signal into a nearly symmetrical square wave with a carrier frequency of 94Hz. Thermistors, located in the DC modulators LED driver circuits, optimize the modulator's performance at ambient temperature extremes.

e. DC modulator driver: The driver is a 2 transistor (3Q1 and 3Q2) oscillator and is adjusted to 94Hz by means of FREQ. ADJ. control (3R11). The oscillator's square wave output powers both the DC modulator and synchronous demodulator via the reference amplifier.

f. Narrow band pre-amplifier and filter: The pre-amp utilizes a high-impedance FET (309) input. Clamping diodes 3CR3 and 3CR4, at the FET's gate, minimizes over-load damage. The three-stage conventional R/C coupled, common emitter amplifier consists of transistors 3Q10, 3Q11 and 3Q12 and their associated circuitry. A tuned parallel "T" narrow band filter network, from the collector of 3Q12 to the base of 3Q10, narrows the amplifier's bandwidth to further improve the signal-to-noise ratio.

g. Post amplifier: This amplifier provides further amplification of the pre-amplifier's output. The two-stage conventional R/C coupled, common emitter amplifier consists of transistors 3Q13 and 3Q14 and their associated circuitry. A GAIN ADJUST control (3R53) at 3Q13's input will adjust the post amplifier's output to optimum. Maximum post amplifier gain is used for 0.001V full scale and 0.003V full scale ranges while a reduced gain is used for the other ranges. Gain reduction is obtained by paralleling resistor 3R54 with resistor 3R55.

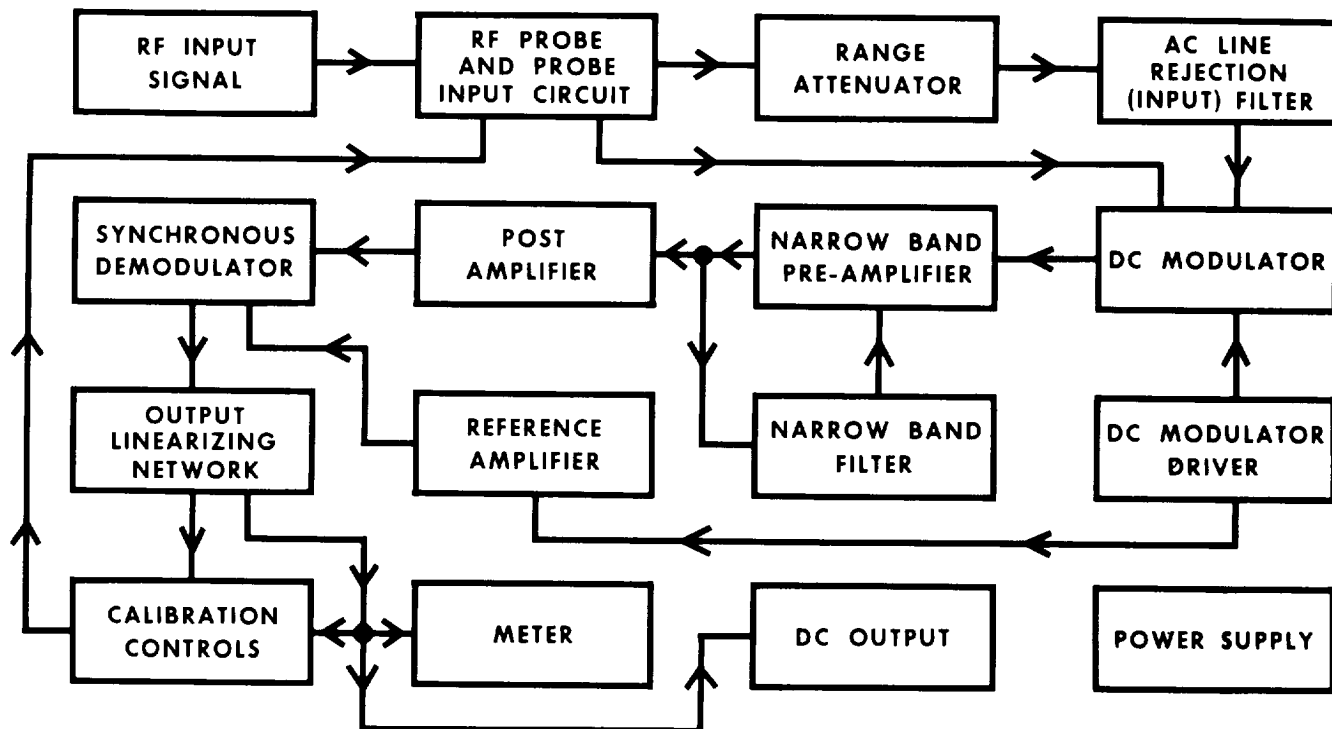

Figure 4-1. Block diagram.

h. Reference amplifier: Emitter follower transistors, 3Q3 and 3Q4, are connected to the DC modulator driver's output. Amplifier transistors, 3Q5 and 3Q6, are direct-coupled to the interstage transformer (3T1). The output of transformer 3T1 is applied to the synchronous demodulator's reference source transistors.

i. Synchronous demodulator: The demodulator's transformer (3T2) compares the modulated signal from the post amplifier's output to the reference amplifier's output. Transistors 3Q7 and 3Q8 provide a phase sensitive reference source for the demodulator. The resulting rectified DC output signal voltage appears at 3T2, Pin 2 and its polarity corresponds to the original signal's output from the probe. A filter capacitor (2C6) removes any AC components while diode 2CR7 dampens and suppresses below SET REF level excursions.

j. Output linearizing network: The network corrects for the non-linear response of the probe's cartridge diodes. Diodes of similar characteristics as the cartridge diodes are placed in the voltmeter's overall feedback loop. These diodes, 2CR5 and 2CR6, along with resistors 2R21 and 2R22 and capacitor 2C5 achieve a linear amplifier output characteristic. The network functions to expand the lower end and compress the upper end of the meter scales. Upper end (HI) and lower end (LO) calibration controls are used in conjunction with the linearizing network. Thermistor, 2RT1, corrects for variations in ambient temperature extremes.

k. Calibration controls: Each measuring range is equipped with three (3) calibration controls. These controls are located on the voltmeter's rear mounted calibration controls board and are screwdriver adjustable. Easy access to the controls is obtained by removing the rear panel cover plate.

The "MID" calibration controls are used to adjust the voltmeter's overall DC feedback voltage. Proper adjustment is made when the meter reads 60% of full scale. Each range's "MID" feedback network consists of a variable resistor ("MID" control) and two (2) resistors in series with it; one (1) located on the calibration control board and the other in the probe.

The "HI" and "LO" calibration controls are used to adjust the 100% and 30% of full scale meter readings, respectively. These two (2) controls are part of the output linearizing network and provide accurate linearization correction adjustments.

For a better understanding of the output linearizing network and calibration controls circuitry, Figure 4-2, linearizing correction network, details the 0.001V full scale range. A brief description follows:

The rectified DC signal voltage, which appears at the synchronous demodulator's output (3T2, Pin 2) is applied to the output linearizing network and calibration controls. Capacitor 2C6 adds filtering while diode 2CR7 dampens and compresses below SET REF excursions.

For readings in the mid meter scale region (50% to 70% of full scale) the response will be nearly linear. The signal splits into two (2) paths; one (1) through the output linearizing network of 2R22, 2R21, 2CR6, 1M1 and 5R1 and the second path through the DC feedback circuit of 4R9, 4R33, 1RT7, 1RT5, 1RT3, 1RT2 and 1RT1, probe resistor (500K) and 3R9. The high resistance of 4R1, 4R35, 2RT1, 2F24 and 2CR5 will prevent current flow through the "HI" network.

The effect of 2CR6 will be to allow current flow through itself and thus bypass the "LO" network. This action keeps the reading nearly linear in this region. The "MID" control (4R9) is adjusted for 60% of full scale indication.

For readings in the upper meter scale region (70% to 100% of full scale) the effects of 2CR5 and 2CR6 become minimal allowing partial current flow through the "HI" linearization correction network. This will act to compress readings in this region. The "HI" control (4R1) is adjusted for 100% of full scale indication.

For readings in the lower meter scale region (30% to 50% of full scale) the resistance of 2CR5 and 2CR6 becomes very high allowing partial current flow through the "LO" linearization correction network. This will act to expand readings in this region. The "LO" control (4R17) is adjusted for 30% of full scale indication.

The meter's input terminal will be shorted to ground when the voltmeter is switched OFF. This helps to prevent electro-static build-up from damaging the meter movement coil while in transit. It also facilitates in mechanically zeroing the meter by removing all potentials from the meter movement coil.

1. DC output: For external monitoring purposes, a 1.0V (1mA max.) linear output voltage is provided at output connector, 5J2. When the external DC output 3 circuit phone plug (furnished as a standard accessory) is inserted, the internal 2K load (5R1) at 5J2 is disconnected. The external monitor must provide the 2K impedance load-and should be within $\pm 1\%$ accuracy to maintain rated' voltmeter specifications.

m. Power supply: The power transformer (2T1) has a 115V/230V AC dual primary input. The full wave rectifier, 2CR1 and 2CR2, is connected to the center-tapped secondary. The rectifier's output is applied to the series regulator transistor (2Q1). Reference voltage for both the series regulator transistor (2Q1) and output amplifier (2Q5) is provided by the reference amplifier (2Q3). A constant current source, 2CR3 and 2CR4, maintains a constant bias at the reference amplifier's base. The inverting amplifier (2Q2) will bias the series regulator transistor's base with an inverted reference voltage. An adjustable voltage divider across the output amplifier's base permits adjustment of the series regulator's output. This electronically regulated power supply delivers a stable and virtually ripple free voltage source regardless of variations in power line voltage (103.5V to 126.5V).

To eliminate inter-action and possible oscillations between the various amplifier boards circuits, local filtering is provided at the AC amplifying stages and DC modulator driver.

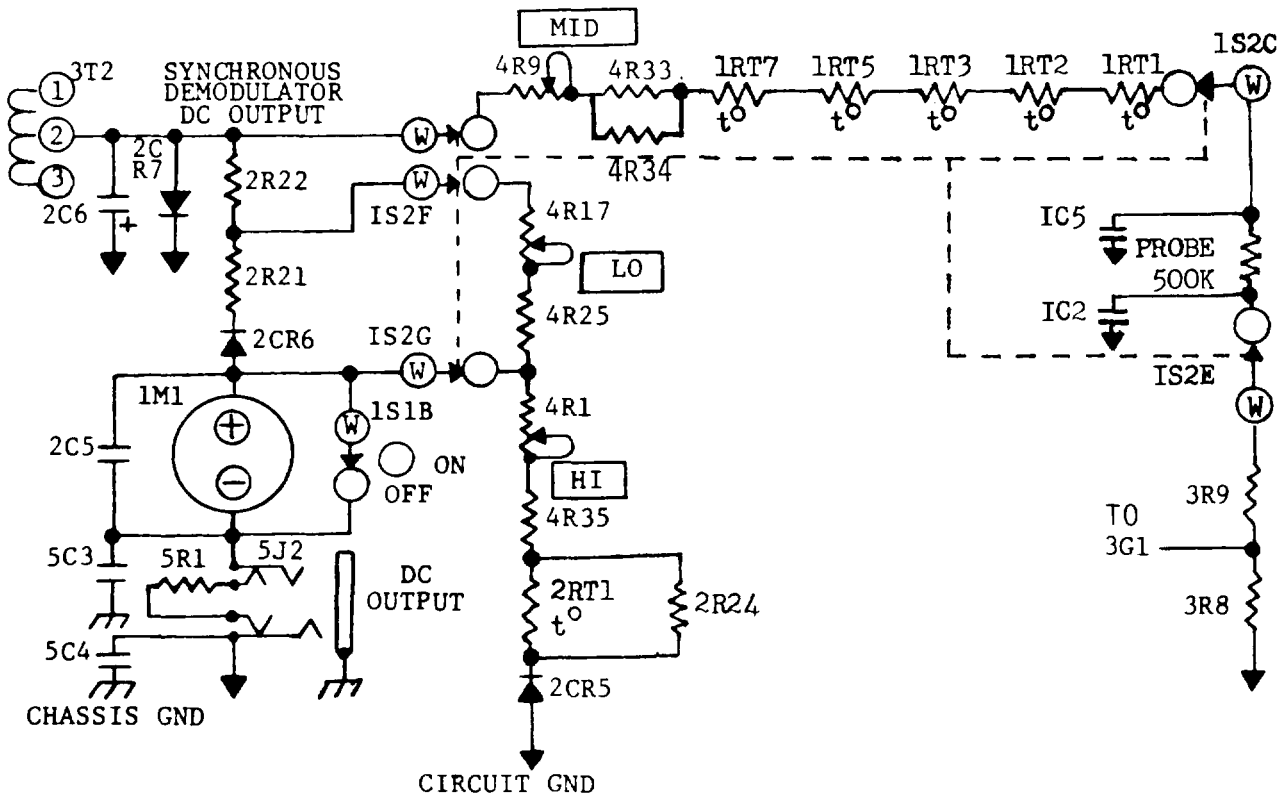

Figure 4-2. Linearizing correction network.

4-3 DETAILED DESCRIPTION, PROBE AND TERMINATIONS

a. Probe: The probe's spring-loaded construction guarantees positive contact with the various threaded accessories. The built-in resistors are epoxy encapsulated and the entire probe and cable assembly are sealed, with the exception of the diode cartridge assembly. The probe should provide years of dependable service. The diode cartridge, being the only part subject to electrical damage, is easily replaced.

b. Diode cartridge: The diode cartridge employs two (2) special, low-capacity, high-stability germanium diodes in a full-wave configuration for RF detection. The measuring capability of the voltmeter covers RF voltages reaching from the square-law region (100µV to 30mV) to the region of linear rectification (1V to 3V). In the square-law region, the voltmeter is true RMS responding, while in the linear region it is peak-responding. In the 30mV to 1V "transition" region, the diode characteristics gradually change from RMS to peak. This non-linear characteristic is true of all diode rectifiers, regardless of design and manufacture. The voltmeter is calibrated in terms of RMS on all 8 ranges.

The diodes have characteristics the user of the voltmeter should be aware of:

1. The shunt resistance of the diodes (probe input impedance) varies inversely with both signal level and frequency. (see figure 4-3)

2. The capacity of the diodes varies inversely with signal level. Probe input capacity varies from approximately 1pf at 3V to 2.2pf at 10mV. (see figure 4-4)

c. Type BNC 50-ohm termination adapter: This is the most widely used termination with a VSWR of less than 1.2:1 to 600MHz. It is not recommended for accurate measurements above this frequency. (see figure 4-5) The termination has a 5 watt power rating.

d. High impedance probe tip: This tip allows high impedance direct measurements up to 250MHz.

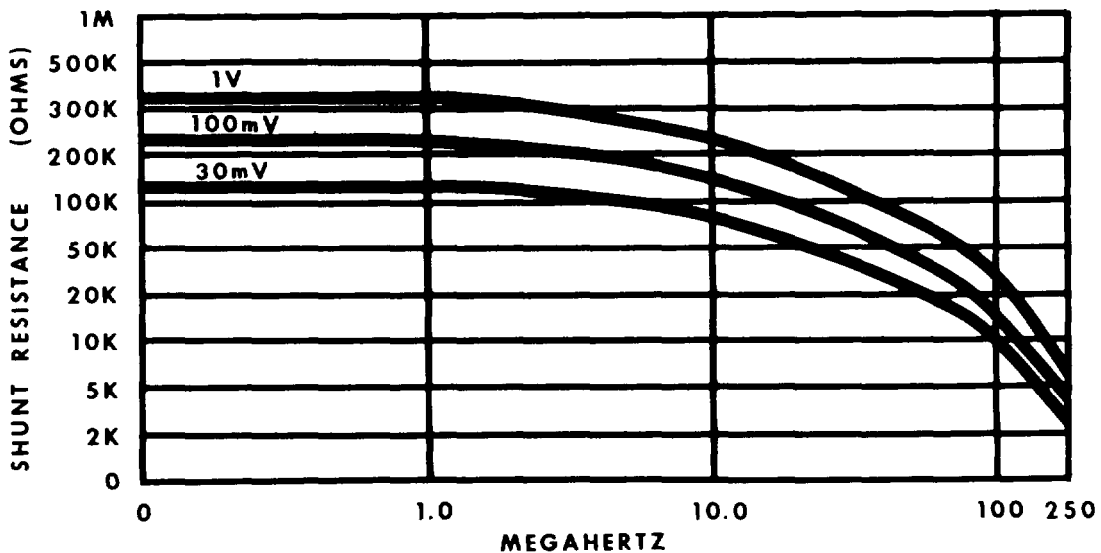

Figure 4-3. Probe input impedance vs. level and frequency.

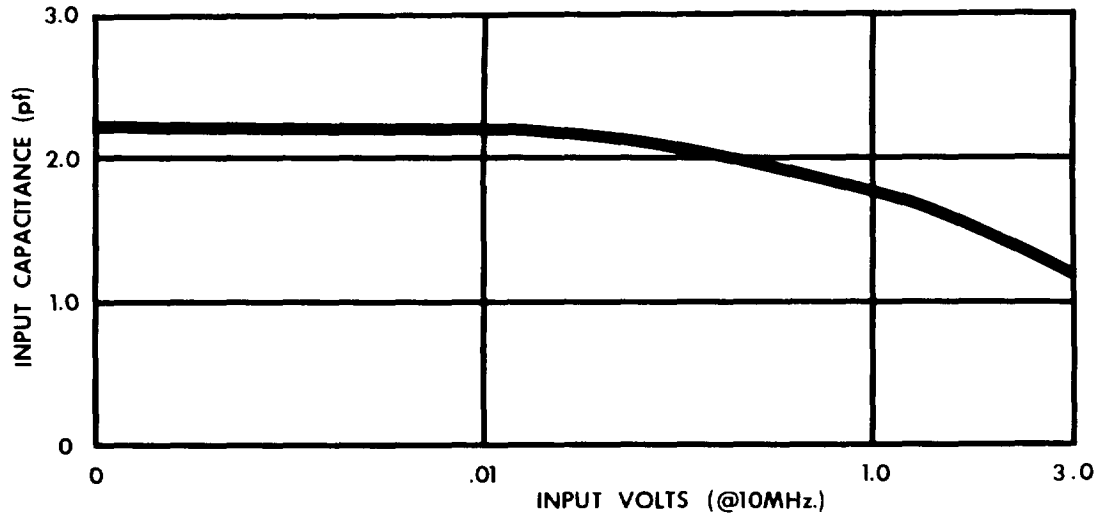

Figure 4-4. Probe input capacitance vs. level.

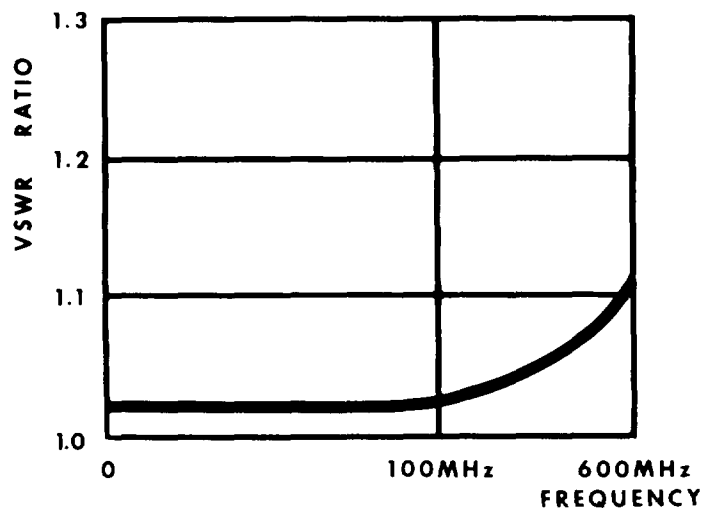

Figure 4-5. VSWR curve for 50-ohm termination adapter.

CHAPTER 5
GENERAL SUPPORT MAINTENANCE INSTRUCTIONS

5-1 TOOLS AND TEST EQUIPMENT REQUIRED.

- a. Tools. No special tools are required.
- b. Test Equipment. The test equipment required for troubleshooting is listed below:

Item	Name	Manufacturer and model number*
A1	Oscillator	Hewlett-Packard 200CD
A2	AC voltmeter	Hewlett-Packard 400EL
A3	Oscilloscope	Tekronix 503
A4	DC multimeter	Millivac 864A

* Equivalent items may be used.

- c. Test equipment set-up. A comprehensive test equipment set-up is shown in figure 5-1 below:

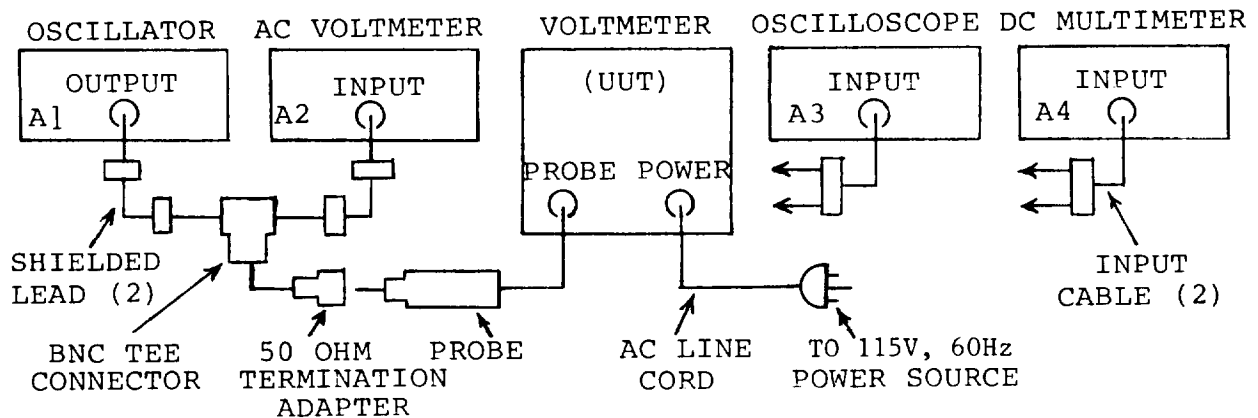

Figure 5-1. Maintenance equipment test setup.

5-2 CABINET REMOVAL

Should maintenance require the removal of the voltmeter's cabinet, the following procedure should be used:

WARNING

HIGH VOLTAGE capable of causing death is used inside this equipment. Use extreme caution when operating or making adjustments inside the equipment.

(1) Disconnect the voltmeter from the AC power line before removing the cabinet.

(2) Removal: Remove the six (6) phillip's panhead screws from the cabinet's lower sides (3 per side) and lift the cabinet straight up to clear the voltmeter. Remove the cabinet's bottom cover plate by taking out the six (6) phillip's panhead screws from the side edges (3 per side) and lifting the plate off.

(3) Shielding: When the voltmeter is to be operated out of its cabinet, adequate shielding will be required to prevent power line and stray AC/RF fields from radiating into the sensitive input circuits. To shield, place aluminum plates of sufficient size to cover the chassis top, bottom and two (2) sides; ground all plates to the chassis.

SECTION II. TROUBLESHOOTING

5-3 GENERAL

a. General. The first procedure in servicing a defective voltmeter is to sectionalize the fault. Sectionalization consists of tracing the fault to a printed circuit board or switch. Once the defective area is located, isolation of the defective part is accomplished. Troubleshooting is performed by general support repair person.

b. Sectionalization. Listed in (1) through (3) below is a group of tests arranged to help locate the defect.

(1) Visual inspection. When the voltmeter is brought in for repair, remove the top cover and inspect as follows:

(a) Check to see that all connections and pc boards are properly seated.

Repair or replace any connections or leads that are broken or otherwise defective.

(b) Check all switches and controls for ease of operation.

(c) Inspect for loose or missing screws.

(2) Operation tests. Operational tests frequently indicate the general location of trouble. In many instances, the tests will determine the exact nature of the fault. The testing procedures in Chapter 6, paragraphs 6-3, 6-4 and 6-5 provide operational tests.

(3) Voltage and resistance measurements. Voltage and resistance measurements are referred to in paragraphs 5-4 through 5-14, as applicable. Several waveforms at critical points are shown in schematic diagrams, F0-1 and F0-2. Use these to localize trouble.

c. Servicing. To aid in servicing the voltmeter, major components and test points are labeled on the printed circuit boards for reference purposes. All circuit boards and components are readily accessible; all solid-state devices including the DC modulator are plug-in socket mounted.

Should component replacement become necessary, replace with the same type and manufacture as factory installed. The component should be replaced in the exact manner and position as the original, otherwise the voltmeter's operating characteristics and accuracies may be altered.

5-4 INOPERATIVE

- a. Check the AC line power source for line voltage and frequency; it should agree with that marked on the serial/power plate. Check the 3 wire grounded AC line power cord for continuity. Check the line fuse for continuity and that it agrees with the ratings as factory specified. Use DC multimeter set to 1X ohms position for continuity checks.
- b. If the pilot light is illuminated but the voltmeter fails to respond to a signal, verify the signal source's output.
- c. Visually check the probe and probe termination for possible damage.
- d. Try another measuring range to determine if the range being used is inoperative.
- e. Any further troubleshooting will require the removal of the voltmeter's cabinet. See paragraph 5-2.
- f. Connect the voltmeter to a 115 volt, 60Hz power source. Set the POWER switch to ON. Using the DC multimeter set to DC volts, check the power supply voltages and compare to those as shown on the schematic diagram, figure F0-2.
- g. Using the DC multimeter set to DC volts, check the amplifier board for DC supply voltages and compare to those as shown on the schematic diagram, figure F0-1.
- h. Disconnect DC multimeter; disconnect voltmeter from power source.

5-5 ERRATIC OR INTERMITTEN

- a. Visually check the probe and probe termination for possible cause.
- b. Try another measuring range to determine if the range being used is inoperative.

Any further checks will require the removal of the voltmeter's cabinet. See paragraph 5-2.

- d. With the cabinet removed, visually inspect for damaged circuit boards, broken wires or loose mechanical parts.
- e. Connect the voltmeter to a 115 volt, 60Hz power source. Set the POWER switch to ON. Using the DC multimeter set to DC volts, check the power supply voltages and compare to those as shown on the schematic diagram, figure F0-2.
- f. Using the DC multimeter set to DC volts, check the amplifier board for DC supply voltages and compare to those as shown on the schematic diagram, figure F0-1.
- g. Disconnect multimeter.

5-6 DC MODULATOR DRIVER

- a. Verify the DC modulator driver's (a 94Hz oscillator) output by measuring the waveshape at the collector of 3Q2 with the oscilloscope and compare to the value as shown on the schematic diagram, figure F0-1. If the output is not within specifications, try substituting 3Q1 and 3Q2 with known good ones.
- b. Check, and if necessary, set the oscillator's frequency to 94Hz by using control 3R11.
- c. Disconnect oscilloscope.

5-7 POST AMPLIFIER, SYNCHRONOUS DEMODULATOR AND REFERENCE AMPLIFIER

The following procedure is used to check the overall performance of these stages:

- a. With the voltmeter properly shielded (see paragraph 5-2) switch to the 0.01V full scale range.
- b. Locate on the amplifier board link wire 3W3. Unsolder one (1) end of 3W3 from 3TP8 and with a short clip lead connect 3TP8 to 3TP10. With another short clip lead connect 3TP13 to 3TP3.

c. The meter should indicate between 30% and 70% of full scale. If the reading fails to reach 30% or exceeds 70% of full scale, the following procedures may be used to check the applicable stages and components.

d. Readjust amplifier board control (3R53) for a meter reading of 50% of full scale.

e. Visually check the meter coil for a sticky movement and/or continuity. If defective, replace.

f. Using the DC multimeter set to DC volts, measure the DC voltages at all applicable transistor stages and compare values to those as shown on schematic diagram, figure F0-1.

g. The synchronous demodulator's transistors, 3Q7 and 3Q8, may be checked by substitution. Transformers 3T1 and 3T2, if suspected of being faulty, should be carefully unsoldered and removed from the circuit board. Their winding continuity should be checked by using the DC multimeter set to ohms.

h. Disconnect 3TP10 from 3TP8 and reconnect link wire 3W3 from 3TP8 and 3TP9. Disconnect 3TP3 from 3TP13.

i. Disconnect multimeter.

5-8 NARROW BAND PRE-AMPLIFIER

a. With the voltmeter properly shielded (see paragraph 5-2) switch to the 0.001V full scale range position. Connect the equipment as shown in figure 5-1. Adjust the oscillator frequency to 200KHz and the output level to 1mV as monitored by the AC voltmeter.

b. Locate on the amplifier board, link 3W3. Unsolder one (1) end of 3W3 from 3TP8.

c. Connect the oscilloscope to 3TP8. Disconnect oscillator from probe. Adjust the SET REF control for minimum amplitude reading on the oscilloscope; the wave-shape should agree with the value as shown on the schematic diagram, figure F0-1.

d. Reconnect the oscillator to the probe. With 1mV applied to the probe, measure the waveshape. It should agree with the value as shown on the schematic. Improper shielding or zeroing may result in large errors.

e. If this check reveals a faulty condition, the following procedure may be used to check each pre-amplifier stage.

f. Using the DC multimeter set to DC volts, measure the DC voltages at each stage's transistor (3Q10, 3Q11 and 3Q12) and compare to those as shown on the schematic diagram, figure F0-1.

g. With the 1mV signal applied, measure with the oscilloscope the gain of each stage. A typical gain figure is 10:1. Should the gain check reveal a defective transistor, verify its condition by substituting with a known good one.

h. Check the forward and reverse resistances of clipping diode (3DR5). Use the DC multimeter set to ohms.

i. Reconnect 3W3 to 3TP8.

j. Disconnect oscilloscope and DC multimeter.

5-9 DC MODULATOR

a. With the voltmeter properly shielded (see Paragraph 5-2), verify the RANGE switch is set to the 0.001V full scale range position.

b. Verify the DC modulator driver is functioning (see paragraph 5-6).

c. To check the modulator's chopping action, deliberately feed a 30mV, 200KHz signal to the probe. With the oscilloscope set to a low level sensitivity, observe the waveshape at 3Q9's gate. If a square-wave is not produced or fails to diminish when the signal source is de-energized, the modulator is probably faulty. If faulty, replace.

d. Disconnect oscilloscope.

5-10 POWER AND RANGE SWITCHES

Should a switch be suspected as being faulty, check the applicable contacts and wiper(s) of the questionable switch section(s) for contact continuity. Also check the wiring continuity between the suspected switch section (s) and their circuit connection (s). Use the DC multimeter set to 1X ohms for continuity checks.

5-11 FEEDBACK, LINEARIZING AND CALIBRATION CONTROL NETWORK

- a. With the voltmeter properly shielded (see paragraph 5-2) verify that all links are connected to their original circuit board connections.
- b. Verify the RANGE switch is set to the 0.001V full scale position.
- c. Disconnect the oscillator from the probe. Adjust the SET REF control (voltmeter) for a meter reading centered about the SET REF line.
- d. Reconnect the oscillator to the probe. Connect the oscilloscope to amplifier board terminal (3TP7). With 1mV applied to the probe, measure the waveshape and compare to that as shown on the schematic diagram, figure F0-1. Should the level greatly exceed that as shown, the network is probably faulty.
- e. The following procedure may be used to troubleshoot the network:
 - f. Check the resistor and thermistor values, diode forward and reverse resistances and the continuity of the network. Use a DC multimeter set to ohms.
 - g. Check the probe for resistance measurements as shown in. Table 5-1. Use the DC multimeter set to ohms.
 - h. Disconnect the equipment as shown in figure 5-1.

SECTION III MAINTENANCE

5-12 PROBE AND DIODE CARTRIDGE

The probe and diode cartridge are factory sealed and their disassembly is not recommended. If defective, replace.

NOTE

Warranty on the probe and diode cartridge is void if tampered with.

If the voltmeter fails to respond to RF signals and all other checks of the trouble shooting sections have been made, the probe and/or diode cartridge may be at fault. Use the following procedure to verify the probe and diode cartridge's condition: With the voltmeter either in its cabinet or properly shielded (see paragraph 5-2) energize and switch to the 0.001V full scale range position. Attach the probe, terminate with the 50-ohm termination adapter but do not connect to a signal source.

Rotate the SET REF control fully clock-wise, a normally operating voltmeter will read between 50% and 100% of full scale. Disconnect the probe from the voltmeter, a normal response is for the meter indicator to drift off-scale in either direction.

Switch to the 0.03V full scale range position. The voltmeter should recover rapidly with the indicator returning to the SET REF position. These tests will verify that the voltmeter is operating normally. The probe and/or probe diode cartridge is then at fault and should be individually tested as follows:

a. Diode Cartridge: Diode failure results from excessive Rr, AC or DC inputs. To test, remove the exposed setscrew on the side of the probe housing, gently slide the cartridge out of the housing (see figure 5-2). Two (2) small spring contacts will be seen on one (1) end of the cartridge, Care should be exercised, not to damage these contacts,. By placing the DC multimeter, set to ohms, across the contacts, a forward-reverse resistance ratio of approximately 800 times should be noted with approximately 5K in the forward direction. Any other reading would indicate a faulty cartridge. If faulty, replace.

To replace the diode cartridge, first remove the grounding spring from the probe housing. The spring may be reused only if clean and undamaged. During manufacture, a thin protective film of white vaseline was applied to all silver-plated surfaces to retard oxidation, Care should be exercised to avoid removal of this film. If the film has been inadvertently removed or if the contacts inside the probe housing have been cleaned, a thin film of white vaseline may be applied to the surface. The cartridge should be carefully inserted into the housing, making certain the slot in the side of the cartridge is aligned with the locking screw hole in the side of the probe housing. The locking screw may now be inserted and tightened, taking care that it properly engages the cartridge slot.

Finally, the grounding spring is inserted (note the correct position as shown in figure 5-2). Positioning the spring may be facilitated by gently pushing the cartridge all the way into the housing several times. When the spring is in its correct position, the fingers will be flush with the edge of the probe housing. With a little thumb pressure, the cartridge should slide smoothly back and forth against the spring-loaded socket assembly inside the probe housing. If it binds and does not fully return after being depressed, the grounding spring fingers may be curved excessively outward. The spring should be removed and the fingers flattened very slightly by pinching them between the smooth area of a pair of long-nosed pliers.

b. Probe: To test, detach from the voltmeter and remove the diode cartridge. With the DC multimeter set to ohms, perform the following resistance checks and compare to the values as shown in Table 5-1.

Table 5-1. Probe resistance checks

Location	Resistance
Plug Pin A to Pin B	10K ±5%
Plug Pin A to Pin C	100K ±5%
Plug Pin A to Pin D	500K ±5%
Plug Pin J to Blue Dot	
Terminal in Probe Housing	10K ±5%
Plug Pin H to Non-Blue Dot	
Terminal in Probe Housing	10K ±5%
Plug Pin J to Pin H	Infinity
Plug Pins A, J and H to Probe Housing Shell	Infinity
Plug Pins E, F and K to Probe Housing Shell	Less than 1Ω

Any discrepancies in the above probe resistance measurements indicates a faulty probe. The probe should be replaced.

5-13 PROBE TERMINATIONS

a. General: The probe terminations are factory sealed and their disassembly is not recommended. If damaged, replace.

b. If a termination is suspected of being faulty, first check that the center pin is making firm contact with the diode cartridge. An increase of mechanical resistance should be noted as the termination is within 1/16" of its final tightened position.

c. Type 50-ohm termination adapter: Check the resistance value of the film resistor using the DC multimeter set to ohms. It should measure 50-ohm (49-ohm to 51-ohm). If out of tolerance, replace.

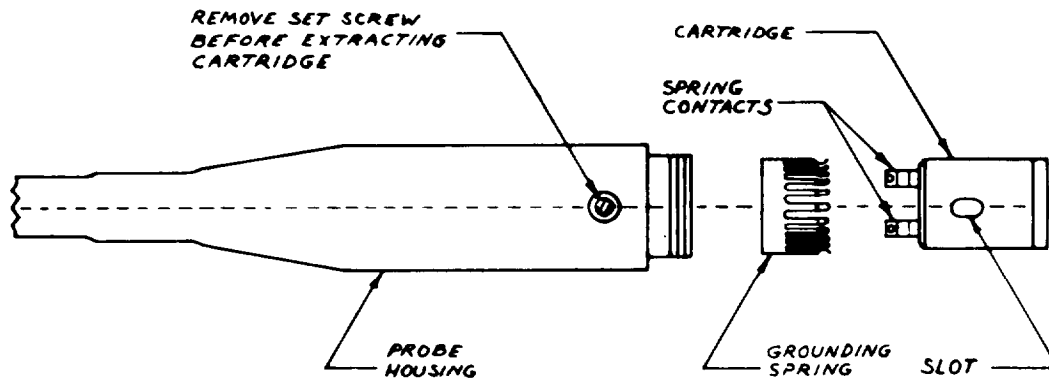

Figure 5-2. Probe and diode cartridge assembly.

5-14 SWITCH CLEANING

A periodic lubrication and cleaning of the switch contact points is necessary for prolonged accurate readings. They may be cleaned if necessary with the tip of a soft cleaning cloth and a minimum of solvent without the disassembly of the switch.

WARNING

Compressed air shall not be used for cleaning purposes except where reduced to less than 29 pounds per square inch (psi) and then only with effective chip guarding and personnel protective equipment. Do not use compressed air to dry parts when TRICHLOROTRIFLUOROETHANE has been used. Compressed air is dangerous and can cause serious bodily harm if protective means or methods are not observed.

WARNING

Adequate ventilation should be provided while using TRICHLORO-TRIFLUOROETHANE. Prolonged breathing of vapor should be avoided. The solvent should not be used near heat or open flame; the products of decomposition are toxic and irritating. Since TRICHLOROTRIFLOURETHANE dissolves natural oils, prolonged contact with skin should be avoided. When necessary, use gloves which the solvent cannot penetrate. If the solvent is taken internally, consult a physician immediately.

CAUTION

The use of TRICHLOROTRIFLOURETHANE on printed circuit boards is not recommended. Limit cleaning with TRICHLOROTRIFLOURETHANE to metal parts of the case and chassis.

CHAPTER 6
GENERAL SUPPORT TESTING PROCEDURES

6-1 GENERAL

These testing procedures are used to determine the acceptability of repaired equipment. These testing procedures set forth specific requirements that the repaired equipment must meet before it is returned to the using organization. Perform the testing procedure steps in sequence, do not vary. All tests to be done with the voltmeter out of its cabinet.

Schematic Diagrams F0-1 and F0-2 should be used as reference sources.

6-2 TEST EQUIPMENT REQUIRED

The test equipment required for general support testing is listed below:

Item	Name	Manufacturer and model number*
A1	Oscillator	Hewlett-Packard 200CD
A2	AC voltmeter	Hewlett-Packard 400EL
A3	Oscillator	Tektronix 503
A4	DC multimeter	Millivac 864A
A5	Variable transformer	Superior Electric power stat 116

*Equivalent items may be used.

6-3 POWER SUPPLY TEST

- a. Test equipment.
 - (1) AC voltmeter
 - (2) Oscilloscope
 - (3) DC multimeter
 - (4) Variable transformer
- b. Test connections: Connect the voltmeter (U.U.T.) to the variable transformer which is connected to a 115-volt, 60Hz source.
- c. Procedure.
 - (1) Set the voltmeter (U.U.T.) to the 3 VOLT full scale range position.
 - (2) Using the AC voltmeter, measure the voltage and adjust the variable transformer's output for 115-volt.
 - (3) On the U. U. T., turn POWER switch to ON.
 - (4) Connect the DC multimeter, set to -30V DC, between power supply board terminals 2TP1 and 2TP2 (2TP2 is the negative side).
 - (5) Measure -13.5V to -15.5V. If not, adjust power supply board control (2R13) until a reading of -14.5V occurs.
 - (6) Disconnect the DC multimeter, reset to -10V DC and reconnect between 2TP1 and chassis (chassis is the negative side).
 - (7) Measure -5.4V to -6.6V.
 - (8) Disconnect the DC multimeter, reset to +10V DC and reconnect between 2TP2 and chassis (chassis is the negative side).

(9) Measure +7.7V to +9.3V.

(10) Disconnect the DC multimeter. Connect the oscilloscope, set to 1 millivolt/centimeter, between 2TP1 and 2TP2.

(11) Measure 0.5mV to 0.0mV of ripple.

(12) Readjust variable transformer's output for 103.5V. There should be no noticeable change in the ripple amplitude.

(13) Readjust variable transformer's output for 126.5V. There should be no noticeable change in the ripple amplitude.

(14) Readjust variable transformer's output for 115V.

6-4 PRE-AMPLIFIER AND POST AMPLIFIER TEST

a. Test equipment.

(1) Oscillator

(2) AC voltmeter

(3) Oscilloscope

b. Test connections: Connect the equipment as shown in figure 6-1.

c. Procedure:

(1) Properly shield the voltmeter (U.U.T.), (see paragraph 5-2).

(2) Adjust the oscillator frequency to 200 KHz and using the AC voltmeter set to 0.001 volt full scale range position, adjust the oscillator's output to 1mV.

(3) Verify the POWER switch is set to ON. Set the RANGE switch to the 0.001 volt full scale range position.

(4) Connect the oscilloscope, set to 5 volt/centimeter, from amplifier board terminal (3TP7) to chassis.

(5) Disconnect oscillator from probe. Adjust the SET REF control voltmeter for minimum amplitude reading on the oscilloscope and should read 1.7 V to 2.3V P-P.

(6) Reconnect the oscillator to the probe. With 1mV applied to the probe, measure on the oscilloscope 13.5V to 16.5V P-P.

(7) Disconnect oscilloscope. Leave other equipment connected in order to perform the voltage accuracy test, paragraph 6-5.

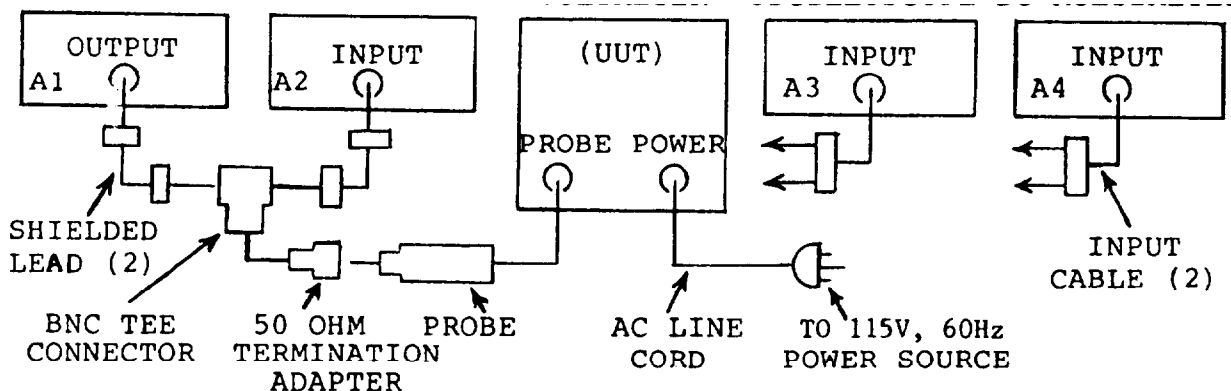

Figure 6-1. Pre-amplifier and post amplifier test setup.

6-5 VOLTAGE ACCURACY TEST

- a. Test, equipment.
 - (1) Oscillator
 - (2) AC voltmeter
- b. Test connections. As connected from paragraph 6-4.
- c. Procedure.
 - (1) On the U. U. T., turn POWER switch to OFF. Adjust the meter's mechanical zero to a meter reading of SET REF.
 - (2) Turn POWER switch to ON.
 - (3) Disconnect oscillator from probe. Adjust the SET REF control (U.U.T.) for a meter reading centered about the SET REF line.
 - (4) Reconnect oscillator to probe.
 - (5) Using the settings listed below, verify the U.U.T. meter indications are within their min./max. voltages. Vary the oscillator output to agree with the applicable AC voltmeter indication. When the U.U.T. is switched to the next range position and for each subsequent range position. adjust the SET REF control prior to applying the oscillator voltage.

Voltmeter (U.U.T.)		AC voltmeter indication		
RANGE switch position (VOLTS)	Meter indication (volts)		(volts)	
	Min.	Max.	Min.	Max.
0.001	0.000582	0.000618	0.000594	0.000606
0.001	0.00097	0.00103	0.00099	0.00101
0.001	0.000291	0.000309	0.000207	0.000303
0.003	0.00194	0.00206	0.00198	0.00202
0.003	0.00201	0.00309	0.00297	0.00303
0.003	0.00097	0.00103	0.00099	0.00101
0.01	0.00582	0.00618	0.00594	0.00606
0.01	0.0097	0.0103	0.0099	0.0101
0.01	0.00291	0.00309	0.00297	0.00303
0.03	0.0194	0.0206	0.0198	0.0202
0.03	0.0291	0.0309	0.0297	0.0303
0.03	0.0097	0.0103	0.0099	0.0101
0.1	0.0582	0.0618	0.0594	0.0606
0.1	0.097	0.103	0.099	0.101
0.1	0.029	0.0309	0.027	0.0303
0.3	0.194	0.206	0.198	0.202
0.3	0.291	0.309	0.297	0.303
0.3	0.097	0.103	0.099	0.101
1.0	0.582	0.618	0.594	0.606
1.0	0.97	1.03	0.99	1.01
1.0	0.291	0.309	0.297	0.303
3.0	1.94	2.06	1.98	2.02
3.0	2.91	3.09	2.97	3.03
3.0	0.97	1.03	0.99	1.01

(6) Disconnect equipment as shown in figure 6-1.

CHAPTER 7
SHIPMENT AND LIMITED STORAGE AND DEMOLITION
TO PREVENT ENEMY USE

Section I. SHIPMENT AND LIMITED STORAGE

7-1 DISASSEMBLY OF EQUIPMENT

Disassemble Voltmeter, Electronic AN/URM-145D as outlined in a, b and c below.

- a. Remove the rf probe from the front panel.
- b. Remove the power cord from the rear panel.
- c. Set the LINE switch to OFF.

7-2 REPACKAGING FOR SHIPMENT OR LIMITED STORAGE

The exact procedure for repackaging depends on the material available and whether the equipment is to be shipped or stored. Adapt the procedures in a, b, and c below whenever possible. The information concerning the original packaging (paragraph 2-1) will be helpful.

a. Material Requirement. The materials listed in the chart below are required for packaging Voltmeter, Electronic AN/URM-145D. For stock numbers of materials, consult SB 38-100.

Material	Quantity
Waterproof paper	6 sq. ft.
Waterproof tape	4 ft.
Corrugated cardboard	6 sq. ft.
Gummed tape	4 ft.
Filler material	3 lbs.

b. Packaging. Pack the cables and adapters in a cardboard carton. Place the cardboard carton on top of the voltmeter. Place pads of filler material on all surfaces. Place the cushioned unit within a wrap of corrugated cardboard.

c. Packing. Wrap the package in waterproof paper, seal it with waterproof tape, and place it in a corrugated cardboard carton.

Section II. DEMOLITION OF MATERIEL TO PREVENT ENEMY USE

7-3 AUTHORITY FOR DEMOLITION

a. The demolition procedures given in paragraph 7-4 will be used to prevent the enemy from using or salvaging this equipment. Demolition of the equipment will be accomplished only upon the order of the Commander.

b. Thorough demolition of equipment will be accomplished through the procedures outlined in International Standardization Agreement STANAG 2113, Destruction of Military Technical Equipment. Methods of destruction should damage equipment and essential spare parts so that it will not be possible to restore the equipment to a usable condition in the combat zone either by repair or cannibalization. Reporting of destruction of equipment is to be done through command channels.

c. If a destruction plan is not provided by higher authority, one should be prepared by the organization using the equipment. In this plan, personnel should be assigned specific destruction tasks, but all personnel in the using organization should be familiar with all aspects of the complete destruction plan. The plan must be adequate and easily carried out in the field and must provide for as complete a destruction as available time, equipment and personnel will permit. Because the

time required for complete destruction may not always be available, the destruction plan must establish priorities so that essential parts of the equipments will be destroyed in the order of their importance. Systematic destruction of the same important units of equipment of a given type will prevent the enemy from learning the important features of the equipment or assembling a complete equipment of cannibalization of partially destroyed equipment. Adequate destruction of some unit of equipment should always be accomplished rather than partial destruction of all units. The method listed in paragraph 8-4 which is to be used depends on the time available for destruction.

7-4 METHODS OF DESTRUCTION

- a. Destruction Priority. STANAG 2113 outlines the general priorities for any equipment which is to be destroyed.
- b. Smash, Smash the controls, resistors, capacitors, switches and other interior parts.
- c. Cut. Cut the cords, cables, and wiring; use axes, handaxes, or machetes.

WARNING

Be extremely careful with explosives and incendiary devices. Use these items only when the need is urgent.

- d. Burn. Burn the cords, wiring, technical manuals and components.
- e. Bend. Bend the panels, casing, and connectors.
- f. Explosives. Use explosives only as necessary.
- g. Disposal. Burn or scatter the destroyed parts in slit trenches, fox-holes or other holes, or throw them into nearby streams.

APPENDIX A

REFERENCES

DA Pam 310-1	Consolidated Index of Army Publications and Blank Forms
SB 38-100	Preservation, Packaging, Packing and Marking Supplies and Equipment used by the Army.
TB 43-0118	Field Instructions for Painting and Preserving Electronics Command Equipment Including Camouflage Pattern Painting of Electrical Equipment Shelters.
TB 43-180	Calibration Requirements for the Maintenance of Army Material,
TB 385-4	Safety Precautions for Maintenance of Electrical/ Electronics Equipment.
TM 11-6625-320-12	Operator's and Organizational Maintenance Manual Voltmeter, Meter ME-30A/U and Voltmeters, Electronic ME-30B/U, ME-30C/U, and ME-30E/U.
TM 11-6625-573-14	Operator's, Organizational, Direct Support and General Support Maintenance Manual for Generator Signal AN/GRM-50 (FSN 6625-868-8353).
TM 11-6625-2658-14	Operator's, Organizational, Direct Support, and General Support Maintenance Manual for Oscilloscope AN/USM-281C (NSN 6625-00-106-9622)
TM 11-6625-2725-14-4	Operator's, Organizational, Direct Support, and General Support Maintenance Manual Including Repair Parts and Special Tools List (Including Depot Maintenance Repair Parts and Special Tools) for Generator Signal AN/URM-127A. (NSN 6625-00-783-5965)
TM 38-750	The Army Maintenance Management System (TAMMS)

TM 740-90-1

Administrative Storage of Equipment

TM 750-244-2

Procedures for Destruction of
Electronics Material to Prevent
Enemy Use (Electronic Command).

APPENDIX B

COMPONENTS OF END ITEM LIST

Section I. INTRODUCTION

B-1. Scope

This appendix lists integral components of AN/URM-145D to help you inventory items required for safe and efficient operation.

B-2. General

This Components of End Item List is divided into the following sections:

a. Section II. Integral Components of End Item. These items comprise the AN/URM-145D and must accompany it whenever it is transferred or turned in. The illustrations will help you identify these items.

b. Section III. Basic Issue Items (Not Applicable).

B-3. Explanation of Columns

a. Illustration. This column is divided as follows:

(1) Figure number. Indicates the figure number of the illustration on which the item is shown.

(2) Item number. The number used to identify item called out in illustration.

b. National Stock Number. Indicates the National stock number assigned to the item and which will be used for requisitioning.

c. Description. Indicates the Federal item name and, if required, a minimum description to identify the item. The part number indicates the primary number used by the manufacturer, which controls the design and characteristics of the item by means of its engineering drawings, specifications, standards, and inspection requirements to identify an item or range of item. Following the part number, the Federal Supply Code for Manufacturers (FSCM) is shown in parentheses.

d. Location. The physical location of each item listed is given in this column. The lists are designed to inventory all items in one area of the major item before moving on to an adjacent area.

e. Usable on Code. (Not Applicable).

f. Quantity Required (Qty Reqd). This column lists the quantity of each item required for a complete major item.

g. Quantity. This column is left blank for use during an inventory. Under the Rcvd column, list the quantity you actually received on your major item. The date columns are for your use when you inventory the major item, at a later date such as for shipment to another site.

(Next printed page is B-3)

B-1/(B-2 blank)

SECTION II INTEGRAL COMPONENTS OF END ITEM
SECTION III BASIC ISSUE ITEMS

(1) ILLUSTRATION A FIG No		(2) NATIONAL STOCK NUMBER	(3) DESCRIPTION (FSCM)	(4) LOCATION	(5) USABLE ON CODE	(6) QTY REQD	(7) QTY
2-1	A	5625-01-119-7271	Voltmeter, Electronic ME-247D/U (MV-828A) 85711			1	
2-1	B	5150-01-004-8773	AC Line Power Cord (800-5121) 85711			1	
2-1	c	6625-00-975-1292	Probe Subassembly MX-10334/URM (900-2002) 85711			1	
2-1	D	5935-00-637-1842	DC Output Phone Plug (60) 82389			1	
2-1	E	6625-90-223-1930	Probe, Subassembly MX-10333/URM 85711			1	
2-1	F	6625-00-470-3717	Lead, Test MX-10334 (900-2000B) 85711			1	
3-2	2	5920-90-235-8362	Fuse 0.3 A S/B 75915 TM 11-6625-524-14-4			1	

Basic Issue Items (Not applicable)

APPENDIX D
MAINTENANCE ALLOCATION

SECTION I. INTRODUCTION

D1 . General

This appendix provides a summary of the maintenance operations for the Voltmeter AN/URM-145D. It authorizes categories of maintenance for specific maintenance functions on repairable items and components and the tools and equipment required to perform each function. This appendix may be used as an aid in planning maintenance operations.

D-2. Maintenance Function

Maintenance functions will be limited to and defined as follows:

- a. Inspect. To determine the serviceability of an item by comparing its physical, mechanical and/or electrical characteristics with established standards through examination.
- b. Test. To verify serviceability and to detect incipient failure by measuring the mechanical or electrical characteristics of an item and comparing those characteristics with prescribed standards.
- c. Service. Operations required periodically to keep an item in proper operating condition, i.e., to clean (decontaminate), to preserve, to drain, to paint, or to replenish fuel, lubricants, hydraulic fluids, or compressed air supplies.
- d. Adjust. To maintain, within prescribed limits, by bringing into proper or exact position, or by setting the operating characteristics to the specified parameters.
- e. Align. To adjust specified variable elements of an item to bring about optimum or desired performance.
- f. Calibrate. To determine and cause corrections to be made or to be adjusted on instruments or test measuring and diagnostic equipments used in precision measurement.
- g. Install. The act of emplacing, seating or fixing into position an item, part, module (component or assembly) in a manner to allow the proper functioning of the equipment or system.
- h. Replace. The act of substituting a serviceable like type part, subassembly or module (component or assembly) for an unserviceable counterpart.

i. Repair. The application of maintenance services (inspect, test, service, adjust, align, calibrate, replace) or other maintenance actions (welding, grinding, riveting, straightening, facing, remachining or resurfacing) to restore serviceability to an item by correcting specific damage, fault, malfunction, or failure in part, subassembly, module (component or assembly), end item or system.

j. Overhaul. That maintenance effort (service/action) necessary to restore an item to a completely serviceable/operational condition as prescribed by maintenance standards (i.e., DMWR) in appropriate technical publications. Overhaul is normally the highest degree of maintenance performed by the Army. Overhaul does not normally return an item to like new condition.

k. Rebuild. Consists of those services/actions necessary for the restoration of unserviceable equipment to a like new condition in accordance with original manufacturing standards. Rebuild is the highest degree of materiel maintenance applied to Army equipment. The rebuild operation includes the act of returning to zero those age measurements (hours, miles, etc.) considered in classifying Army equipments/components.

D-3. Column Entries

a. Column 1, Group Number. Column 1 lists group numbers, the purpose of which is to identify components, assemblies, subassemblies and modules with the next higher assembly.

b. Column 2, Component/Assembly. Column 2 contains the noun names of components, assemblies, subassemblies and modules for which maintenance is authorized.

c. Column 3, Maintenance Functions. Column 3 lists the functions to be performed on the item listed in column 2. When items are listed without maintenance functions, it is solely for purpose of having the group numbers in the MAC and RPSTL coincide.

d. Column 4, Maintenance Category. Column 4 specifies, by the listing of a "work time" figure in the appropriate subcolumn(s), the lowest level of maintenance authorized to perform the function listed in column 3. This figure represents the active time required to perform that maintenance function at the indicated category of maintenance. If the number or complexity of the tasks within the listed maintenance function vary at different categories, appropriate "work time" figures will be shown for each category. The number of task-hours specified by the "work time" figure represents the average time required to restore an item (assembly, subassembly, component, module, end item or system) to a serviceable condition under typical field operating conditions. This time includes preparation time, troubleshooting time, and quality assurance/quality control time in addition to the time required to perform the specific tasks identified for the maintenance functions authorized in the Maintenance

Allocation Chart. Subcolumns of column 4 are as follows:

- C - Operator/Crew
- O - Organizational
- F - Direct Support
- H - General Support
- D - Depot

e. Column 5, Tools and Equipment. Column 5 specifies by code, those common tool sets (not individual tools) and special tools, test and support equipment required to perform the designated function.

f. Column 6, Remarks. Column 6 contains an alphabetic code which leads to the remark in section IV, Remarks, which is pertinent to the item opposite the particular code.

D-4. Tool and Test Equipment Requirements (Sect. III).

a. Tool or Test Equipment Reference Code. The numbers in this column coincide with the numbers used in the tools and equipment column of the MAC. The numbers indicate the applicable tool or test equipment for the maintenance functions.

b. Maintenance Category. The codes in this column indicate the maintenance category allocated the tool or test equipment.

c. Nomenclature. This column lists the noun name and nomenclature of the tools and test equipment required to perform the maintenance functions.

d. National/NATO Stock Number. This column lists the National/NATO stock number of the specific tool or test equipment.

e. Tool Number. This column lists the manufacturer's part number of the tool followed by the Federal Supply Code for manufacturers (5-digit) in parentheses.

D-5. Remarks (Sect. IV).

a. Reference Code. This code refers to the appropriate item in section II, column 6.

b. Remarks. This column provides the required explanatory information necessary to clarify items appearing in section II.

SECTION II MAINTENANCE ALLOCATION CHART
FOR
VOLTMETER, ELECTRONIC AN/URM-145D

(1) GROUP NUMBER	(2) COMPONENT/ASSEMBLY	(3) MAINTENANCE FUNCTION	(4) MAINTENANCE CATEGORY					(5) TOOLS AND EQPT.	(6) REMARKS
			c	o	F	H	D		
00	VOLTMETER, ELECTRONIC AN/URM-145D								
01	VOLTMETER, ELECTRONIC ME-247D	Inspect Service Repair Inspect Replace Calibrate Align Repair		0.2 0.5 0.2		0.3 0.2 0.6 0.2 0.5		Visual 9 9 Visual 8 1 thru 4,7 1,5 8	A B C D E F G
0101	POWER SUPPLY	Test Repair Ad-just				0.4 0.8 0.1		1,2,5 1 thru 8 1,5	H I
0102	PREAMPLIFIER AND AMPLIFIER	Test Repair Adjust				0.6 0.8 0.2		1,2,4,6 1 thru 8 1,2,4	J

SECTION III TOOL AND TEST EQUIPMENT REQUIREMENTS
FOR
VOLTMETER, ELECTRONIC AN\URM-145D

TOOL OR TEST EQUIPMENT REF CODE	MAINTENANCE CATEGORY	NOMENCLATURE	NATIONAL/NATO STOCK NUMBER	TOOL NUMBER
1	H	VOLTMETER, ELECTRONIC ME-30/U	6625-00-643-1670	HP334A
2	H	OSCILLOSCOPE, AN/USM-281C	6625-00-106-9622	TEK5440
3	H	GENERATOR, SIGNAL AN/GRM-50	6625-00-003-3238	HP8640B
4	H	OSCILLATOR, AN/URM-127A	6625-00-783-5722	HP652A
5	H	TRANSFORMER, VARIABLE, CN-16/U	5950-00-688-5722	W010MT3
6	H	ADAPTER, MILLIVAC #900-2100		
7	H	CABLE ASSEMBLY, RF-CG-409H/U (2 required)	5995-00-070-8747	
8	H	TOOL KIT, ELECTRONIC EQUIPMENT TK-100/G	5180-00-605-0079	
9	0	TOOLS AVAILABLE TO THE ORGANI- ZATION BECAUSE OF THE ASSIGNED MISSION.		

SECTION IV. REMARKS
 VOLTMETER, ELECTRONIC AN/URM-145D

REFERENCE CODE	REMARKS
A	External receptacles, meter glass, knobs, controls, and switches for proper action, cables for cuts, cracks or fraying, external hardware, rust and corrosion.
B	Clean exterior surfaces, remove dirt, grease and fungus, rust and corrosion. Apply touchup paint.
C a	Repair through replacement of burned out fuse and defective knobs.
D	Loose or missing hardware; check switches, controls, connections and printed circuit boards.
E	Replace missing or defective hardware.
F	Operational checks to localize troubles. Voltage and Resistance measurements, Voltage accuracy tests.
G	Voltage adjustments.
H	Voltage and ripple tests.
I	Output voltage adjustments.
J	Noise, voltage and waveshape tests.

D-7/(D-8 blank)

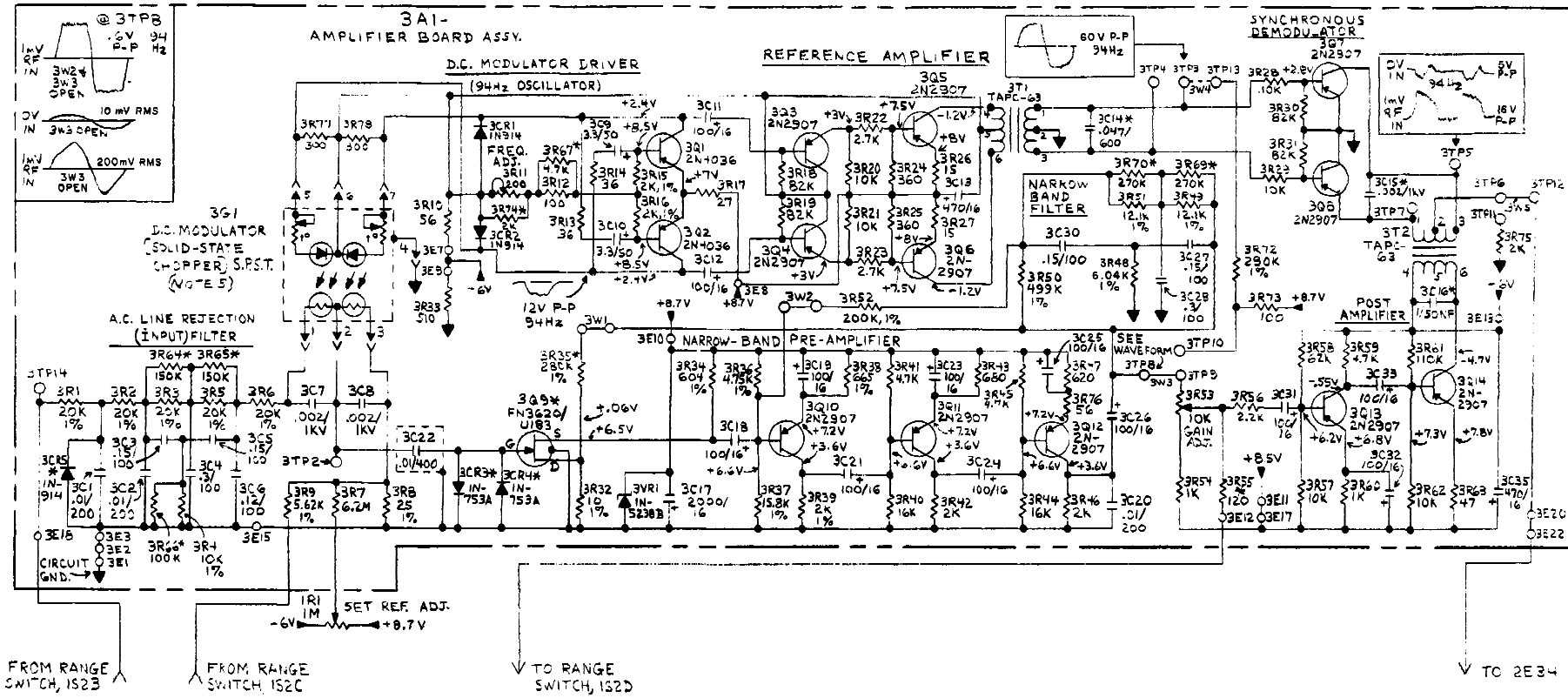

- NOTES:**
- COMPONENT PREFIX DESIGNATIONS
 1 CHASSIS AND SWITCHES
 2 POWER SUPPLY BOARD
 3 MAIN AMPLIFIER BOARD
 4 CALIBRATION BOARD
 5 SERIAL/POWER PLATE
 E CIRCUIT BOARD TERMINAL PADS
 INTERCONNECTING WIRES
 - UNLESS OTHERWISE SPECIFIED:
 A. FIXED RESISTORS IN CHMS, 5% 1/2W
 B. CAPACITORS IN MFD/VOLTS
 - * ASTERISK DENOTES SELECTED AT MANUFACTURE COMPONENT, NOMINAL VALUE SHOWN
 - VOLTAGE AND WAVE SHAPE VALUES:
 A. MADE WITH RESPECT TO CHASSIS GND.
 B. MADE WITH 115V/60HZ AC LINE TYPICAL

FO-1
 SCHEMATIC DIAGRAM
 OF AMPLIFIER BOARD
 ASSEMBLY
 EL6625-524-14-TM-13

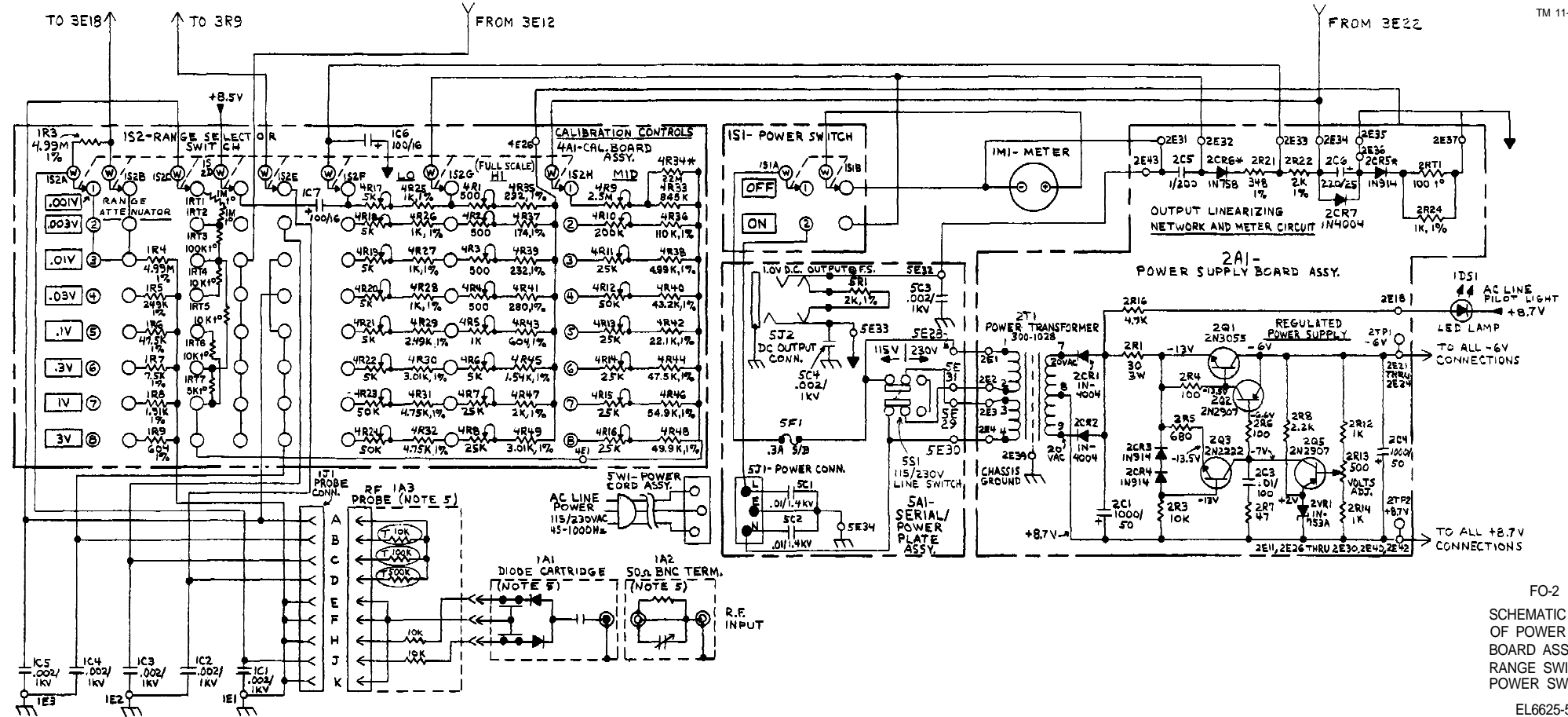

FO-2
 SCHEMATIC DIAGRAM
 OF POWER SUPPLY
 BOARD ASSEMBLY,
 RANGE SWITCH AND
 POWER SWITCH

RECOMMENDED CHANGES TO EQUIPMENT TECHNICAL PUBLICATIONS



THEN... JOT DOWN THE DOPE ABOUT IT ON THIS FORM. CAREFULLY TEAR IT OUT. FOLD IT AND DROP IT IN THE MAIL!

SOMETHING WRONG WITH THIS PUBLICATION?

FROM (PRINT YOUR UNIT'S COMPLETE ADDRESS)
 Commander
 Stateside Army Depot
 ATTN: AMSTA-US
 Stateside, N.J. 07703

DATE SENT
 4 April 1978

PUBLICATION NUMBER
 TM 11-5840-340-14&P

PUBLICATION DATE
 23 Jan 74

PUBLICATION TITLE
 Radar Set AN/PRC-76

BE EXACT PIN-POINT WHERE IT IS

PAGE NO	PARA-GRAPH	FIGURE NO	TABLE NO
2-25	2-28		
3-10	3-3		3-1
5-6	5-8		
E-5			
E-8		E-3	
E-9			

IN THIS SPACE TELL WHAT IS WRONG AND WHAT SHOULD BE DONE ABOUT IT:

Recommend that the installation antenna alignment procedure be changed throughout to specify a 2° IFF antenna lag rather than 1°.

REASON: Experience has shown that with only a 1° lag, the antenna servo system is too sensitive to wind gusting in excess of 25 knots, and has a tendency to rapidly accelerate and decelerate as it hunts, causing strain to the drive train. Hunting is minimized by adjusting the lag to 2° without degradation of operation.

Item 5, Function column Change "2 db" to "3db."

REASON: The adjustment procedure the TRANS POWER FAULT indicator calls for a 3 db (500 watts) adjustment to light the TRANS POWER FAULT indicator.

Add new step f.1 to read, "Replace cover plate removed in step e.1, above."

REASON: To replace the cover plate.

For item 2, change the NSN to read: 5835-00-134-9186.

REASON: Accuracy.

Identify the cover on the junction box (item no. 5).

REASON: It is a separate item and is not called out on figure 19.

Add the cover of the junction box as an item in the listing for figure 19.

REASON: Same as above.

PRINTED NAME GRADE OR TITLE AND TELEPHONE NUMBER
 SSG I. M. DeSpiritof 999-1776

SIGN HERE

TEAR ALONG PERFORATED LINE

RECOMMENDED CHANGES TO EQUIPMENT TECHNICAL PUBLICATIONS

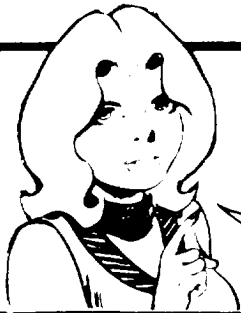

THEN...JOT DOWN THE DOPE ABOUT IT ON THIS FORM. CAREFULLY TEAR IT OUT, FOLD IT AND DROP IT IN THE MAIL.

SOMETHING WRONG WITH THIS PUBLICATION?

FROM: (PRINT YOUR UNIT'S COMPLETE ADDRESS)

DATE SENT

PUBLICATION NUMBER

PUBLICATION DATE

PUBLICATION TITLE

BE EXACT PIN-POINT WHERE IT IS

PAGE NO

PARA-GRAPH

FIGURE NO.

TABLE NO.

IN THIS SPACE TELL WHAT IS WRONG AND WHAT SHOULD BE DONE ABOUT IT:

TEAR ...ONG PERFORATED LINE

PRINTED NAME GRADE OR TITLE AND TELEPHONE NUMBER

SIGN HERE

DA FORM 2028-2
1 JUL 79

PREVIOUS EDITIONS ARE OBSOLETE

P.S.--IF YOUR OUTFIT WANTS TO KNOW ABOUT YOUR RECOMMENDATION MAKE A CARBON COPE OF THIS AND GIVE IT TO YOUR HEADQUARTERS.

FILL IN YOUR
UNIT'S ADDRESS

FOLD BACK

DEPARTMENT OF THE ARMY

OFFICIAL BUSINESS
PENALTY FOR PRIVATE USE \$300

POSTAGE AND FEES PAID
DEPARTMENT OF THE ARMY
DOD 314



TEAR ALONG
DASHED LINE

Commander
US Army Communications-
Electronics Command and Fort Monmouth
ATTN: DRSEL-ME-MP
Fort Monmouth, New Jersey 07703

FILL IN YOUR
UNIT'S ADDRESS

FOLD BACK

TEAR ALONG

DEPARTMENT OF THE ARMY

OFFICIAL BUSINESS
PENALTY FOR PRIVATE USE \$300

POSTAGE AND FEES PAID
DEPARTMENT OF THE ARMY
DOD 314



JANDED LINE

Commander
US Army Communications-
Electronics Command and Fort Monmouth
ATTN: DRSEL-ME-MP
Fort Monmouth, New Jersey 07703

RECOMMENDED CHANGES TO EQUIPMENT TECHNICAL PUBLICATIONS



THEN...JOT DOWN THE DOPE ABOUT IT ON THIS FORM. CAREFULLY TEAR IT OUT, FOLD IT AND DROP IT IN THE MAIL.

SOMETHING WRONG WITH THIS PUBLICATION?

FROM: (PRINT YOUR UNIT'S COMPLETE ADDRESS)

DATE SENT

PUBLICATION NUMBER

PUBLICATION DATE

PUBLICATION TITLE

BE EXACT PIN-POINT WHERE IT IS

PAGE NO.

PARA-GRAPH

FIGURE NO.

TABLE NO.

IN THIS SPACE TELL WHAT IS WRONG AND WHAT SHOULD BE DONE ABOUT IT:

LONG PERFORATED LINE

PRINTED NAME GRADE OR TITLE AND TELEPHONE NUMBER

SIGN HERE

DA FORM 2028-2
1 JUL 79

PREVIOUS EDITIONS ARE OBSOLETE

P.S.--IF YOUR OUTFIT WANTS TO KNOW ABOUT YOUR RECOMMENDATION MAKE A CARBON COPE OF THIS AND GIVE IT TO YOUR HEADQUARTERS.

FILL IN YOUR
UNIT'S ADDRESS

FOLD BACK

TEAR ALONG

DEPARTMENT OF THE ARMY

POSTAGE AND FEES PAID
DEPARTMENT OF THE ARMY
DOD 314



TEAR LINE

OFFICIAL BUSINESS
PENALTY FOR PRIVATE USE \$300

Commander
US Army Communications-
Electronics Command and Fort Monmouth
ATTN: DRSEL-ME-MP
Fort Monmouth, New Jersey 07703

By Order of the Secretary of the Army:

EDWARD C. MEYER
General, United States Army
Chief of Staff

Official:

ROBERT M. JOYCE
Brigadier General, United States Army
The Adjutant General

DISTRIBUTION:

To be distributed in accordance with special list.

